

INSIGHT

Dimaterials



TOTAL EMC / THERMAL PRODUCTS



■ Homepage : www.dimaterials.co.kr

■ E-mail : dim@dimaterials.co.kr



CONTENTS

Company Introduction ----- 4

01_ Electromagnetic Wave Absorber ----- 6

- Standard type
- High Thermal Resistance type
- High Frequency Band
- Double and Wide Band
- Thermal EMI Absorber

02_ Thermal Interface Material ----- 14

- Gel type
- Sheet type
- Grease type

03_ Silicone Foam ----- 21

- IDSF type

04_ Conductive Elastomer ----- 23

- Mold type
- Extrusion type

05_ Conductive Paste	29
• Dispensing Gasket	
• Conductive Paste	
06_ SMT Gasket	35
• IDSMT & IDCF series	
07_ Shielding Gasket	41
• Fabric Gasket	
• Cushion Gasket	
08_ Conductive Fabric & Tape	47
• Conductive Fabric	
• Conductive Tape	
09_ Metal Clip	53
• Finger Strip	
• SMD Finger	
10_ Shield Window	61
11_ EMI Air Vent Filter	64
• Honeycomb type	



DI materials CORPORATION

Introduction

DI materials is one of the leading manufacturer of EMC/Thermal business in Korea. In order to satisfy the rapidly growing global demands, especially in the telecommunication and electronic industries, DI materials offers high quality, competitive price and timely delivery.

DI materials will meet the needs required from customers, and cooperate with demands.

Philosophy

DI materials's philosophies are;
to satisfy the customers
to meet the requirements
to hear your idea

Services

- Best Lead Time
- Best Technical Support
- Best Price

Factories

1. Head Office, R&D Center and Production Div.

36, Ansantekom 1-gil, Sangnok-gu, Ansan-si, Gyeonggi-do, Republic of Korea

2. Banwol Factory

98-10, Neungan-ro, Danwon-gu, Ansan-si, Gyeonggi-do, Republic of Korea

3. Gumi Business Office

6, Indong 54-gil, Gumi-si, Gyeongsangbuk-do, Republic of Korea

4. DI materials Vietnam Corp.

Lot CN1-2 and CN1-3, Yen Phong Industrial Park (expansion phase),
Yen Trung and Dung Liet Communes, Yen Phong District, Bac Ninh Province, Vietnam

Profile

- 2006. 08 Established Doosung Industrial corporation
- 2007. 03 Purchased the second factory for business expanding Obtained the UL certification
- 2007. 04 Obtained the ISO 9001 & 14001 certifications
- 2007. 07 Contracted MOU with 3M to supply products Established the R&D Center
- 2007. 12 Achieved the venture listed company
- 2008. 05 Certified a new material developed company
- 2009. 02 Won the 16th best trader of the month awarded by KITA
- 2009. 06 Took over two R&D projects from the government
- 2009. 11 Won the tower of export(\$5 million) awarded by KITA
- 2010. 04 Established Doosung Electronics (Suzhou)Co., Ltd. in China
- 2011. 11 Won The Korea Economic Daily Commendation for IT Patent Management
- 2012. 04 Jang, Il-sun was inaugurated as CEO
- 2012. 10 New Investment in EMC/EMI Plating Factory & its Relocation
- 2017. 10 Established Doosung Electronics (Suzhou) Co.,Ltd. Dongguan Office
- 2018. 12 Relocation and expansion of headquarters
- 2022. 02 Obtain IATF16949 certification
- 2022. 03 CEO Lae-Won. Kim takes office
- 2022. 04 Changed company name to "DI materials Corporation"
- 2024. 05 Establishment of silicone foam manufacturing line at Banwol factory
- 2025. 04 Establishment of DI Materials Vietnam Corporation

Certifications

• ISO 9001



Certificate No. : QMC-1356

• ISO 14001



Certificate No. : EMC-0538

• ISO 45001



Certificate No. : SMC-2110

• IATF 16949



Certificate No. : KIWA-19961-T

• UL



• Certificate of Research & Development



Electromagnetic Wave Absorber

INSIGHT
DImaterials

Our Absorbers effectively suppress radiated noise on various frequency ranges. These Series improve the distance of electromagnetic signal recognition. Our Absorbers can be customized according to frequency range and absorbing rate. Various shapes & sizes are available on request.

Standard EMI Absorber

- IDA series

High thermal resistance type EMI Absorber

- IDSOB series

High frequency band EMI Absorber

- IDCI series

Double and Wide band EMI Absorber

- IDCIM series

Thermal EMI Absorber

- IDCI-T series
- IDCI-F series



● Introduction

The compatibility of electronic devices with various electromagnetic environment has become an important issue in recent years.

DI materials has developed the IDA-series Absorbers manufactured based on our technologies and know-how accumulated, which are lightweight and flexible. Much absorption loss provides you with wide applications in the EMI/EMC field such as mobile phones, LCD cables, military applications and the SAR issues.

● Applications

- Suppressing radiated noise and its internal interference of electronic devices
- Intra-system application to suppress noise in quasi-microwave range
- Improving the distance of electromagnetic signal recognition and preventing interference between loop antennas and adjacent metal objects
- Communication devices, office electronics, computers, home appliances, and devices mounted on automobiles, radar and TV ghost measures, ETC (the electronic toll collection system), wireless equipment, military applications, etc.

● Features

- Excellent electromagnetic absorption performance in the microwave ranges
 - Thin, lightweight, flexible; reliable in wide applications
 - High permeability performed excellently in noise suppression
 - The applicable frequency range; quasi-microwave band, C{4~8GHz}, X{8~12.5GHz}, Ka, K band
 - High electrical & thermal resistance
 - Various shapes and sizes are available on request.
-

● Effect

Concept of RF Absorber

IDA-Series absorbers are to absorb the energy of electromagnetic noise and to transfer it into heat.

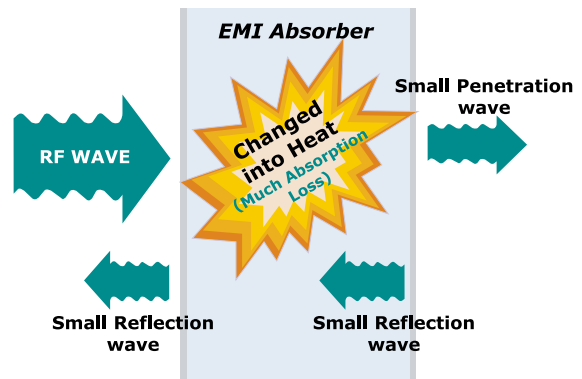

Electromagnetic Shield

Absorber can prevent interactive interference between the neighboring PCBs and/or FPCBs

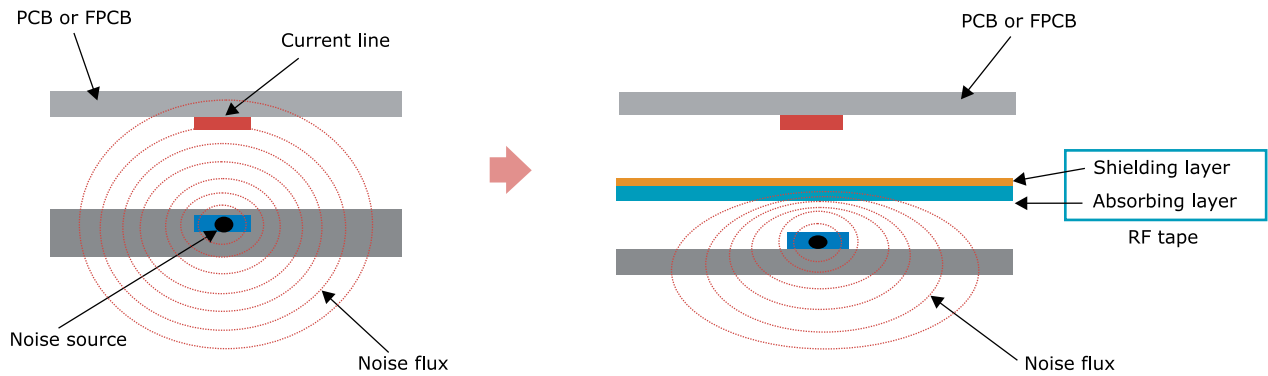

● NFC/RFID Application

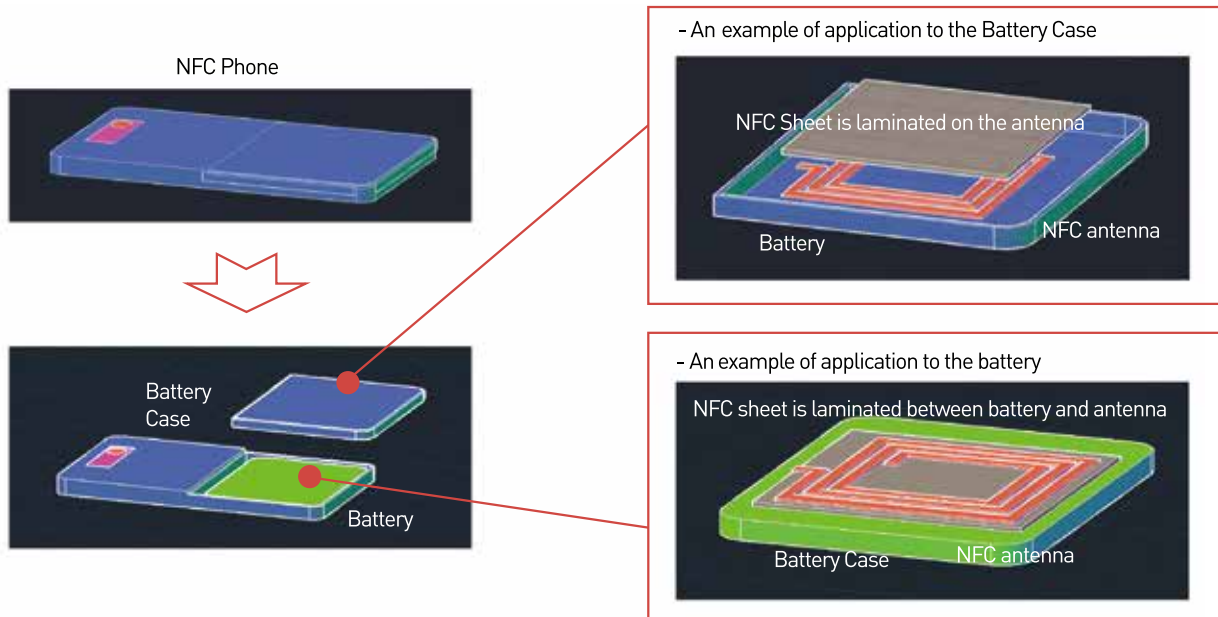

IDA series - Standard EMI Absorber

Features

- Roll type product filled with high efficiency metal; excellent function of absorption and suppression of electromagnetic wave noise
- Feasible to cope with optimum product by frequency band as application of various fillers.
- Thin, lightweight, flexible; reliable in wide applications
- Possible to supply eco-friendly products as developing halogen free product



Structure



Specifications

Content	EMI Absorber								NFC/RFID			GHz band
	N	VHFR	VHF	FM	N2	FML	FMP	GMP	R	RP	RQ	WP
Target frequency	10MHz ~ 4GHz								13.56MHz			1GHz ~ 10GHz
Material	Soft magnetic metal powder + Rubber								Complex sheet			
Thickness (mm)	0.1 ~ 1.0	0.1 ~ 0.5	0.1 ~ 1.0		0.05 ~ 0.5				0.1 ~ 0.5	0.1 ~ 1.0	0.05 ~ 0.3	0.05 ~ 0.3
Standard size	Roll (210mm×M), Custom size		210mm×300mm, 300mm×420mm, Custom size		300mm × 300mm			Roll (210mm ×M)	300mm×420mm, Custom size	300mm × 300mm	300mm × 300mm	
Permeability	30	50	50	100	110	150	200	250	30	55	65	25
Environment	RoHS / Halogen Free								RoHS / Halogen Free			
Service temp. (°C)	-25 ~ 90		-25 ~ 120		-25 ~ 90		-25 ~ 110		-25 ~ 90	-25 ~ 120	-25 ~ 90	

How to Order

P/N : IDA - AAA - BBB - CCC - DDD - EEE - FFF

① ② ③ ④ ⑤ ⑥

- ① Serial Number : N, VHFR, VHF, FM, N2, FML, FMP, GMP, R, RP, RQWP
- ② Thickness (mm) : 100 = 1.00mm, 010 = 0.10mm, 001 = 0.01mm
- ③ Width (mm)
- ④ Length (mm)
- ⑤ Tape Type : A(100 μ m), A1(50 μ m), A2(30 μ m), A3(20 μ m), C(none)
- ⑥ None : Rectangular type, S : Shape type

[For Example]

IDA-N2-100-210-300-A-S

- ▶ Thickness : 1.00mm
- ▶ Width : 210mm
- ▶ Length : 300mm
- ▶ Tape Type : A
- ▶ S : Shape type

IDSOB series - High thermal resistance type EMI Absorber

Features

- A composite body in the form of a sheet made with blending and dispersing micron-sized magnetic fillers in a polymeric binder system
- The applicable frequency range is from 10MHz to 6GHz, or so.
- Electromagnetic noise reduction for the internal EMI and resonance of electronic equipment



Structure

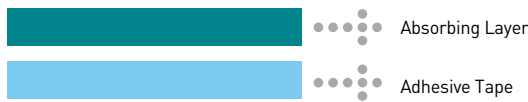

Specifications

Item	IDSOB series			
	V0 (for 800MHz)	V1 (for 1.5GHz)	V2 (for 2.5GHz)	V3 (for 3.5GHz)
Content	These frequencies can be applied at 1.0mm thick of respective absorbers			
Material	Microwave absorbing material + Elastomer (High thermal resistance type)			
Thickness (mm)	0.15 ~ 10.0			
Frequency Range	400MHz ~ 6GHz			
Standard Size(mm × mm)	210 × 300 (If you want different thickness and shape of IDSOB, please contact us)			
Surface Resistance (Ω)	Min 1.0×10 ⁹			
Hardness (Shore A)	85 (±5)			
Density (g/cm ³)	3.8 (±0.5)			
Service Temp. (°C)	-30 ~ 150			
Tensile Strength (kgf/cm ² / psi)	V0 [20 / 284.2], V1 [28 / 397.9], V2 [35 / 497.4]			
Flammability	Non Flammable			
Option	Adhesive Tape / Conductive Mesh Tape			

How to Order

P/N : IDSOB - AAA - BBB - CCC - DDD - EEE - FFF

① ② ③ ④ ⑤ ⑥ ⑦

- ① Serial Number
- ② Thickness (mm) : 100=1.00mm, 010=0.10mm, 001=0.01mm
- ③ Frequency : V0(800MHz), V1(1.5GHz), V2(2.5GHz), V3(3.5GHz)
- ④ Width (mm)
- ⑤ Length (mm)
- ⑥ Tape Type : A(100 μ m), A1(50 μ m), A2(30 μ m), A3(20 μ m), C(none)
- ⑦ None : Rectangular type, S : Shape type

[For Example]

IDSOB-150-V0-210-300-A

- ▶ Thickness : 1.50mm
- ▶ Frequency : V0(800MHz)
- ▶ Width : 210mm
- ▶ Length : 300mm
- ▶ Tape Type : A
- ▶ None : Rectangular type

IDCI series - High frequency band EMI Absorber

Features

- The frequency range : (0.5~8GHz), X(8~12GHz), Ka, K band
- Excellent absorbing performance at the wide frequency
- Flexible and easy to apply

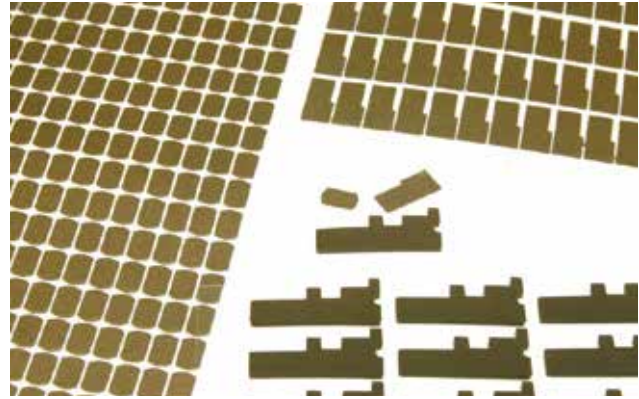

Structure



Specifications

Content	Item	IDCI series							
		IDCI-050	IDCI-100	IDCI-150	IDCI-200	IDCI-250	IDCI-300	IDCI-350	IDCI-400
Thickness (mm)		0.5 (±0.1)	1.0 (±0.1)	1.5 (±0.2)	2.0 (±0.2)	2.5 (±0.3)	3.0 (±0.3)	3.5 (±0.4)	4.0 (±0.4)
Frequency Range		5GHz ~ 40GHz				500MHz ~ 20GHz			
Hardness (Shore A)		70 ± 10 (for Standard type)							
Service Temp. (°C)		-30~150							
Standard Size		210mm × 300mm							
Flammability		Non Flammable							
Surface Resistance (Ω)		Min 1.0 × 10 ⁸							
Density (g/cm ³)		3.8 ± 1.0 (for Standard type)							

How to Order

P/N : IDCI - AAA - BBB - CCC - DDD - EEE - FFF

① ② ③ ④ ⑤ ⑥ ⑦

- ① Serial Number
- ② Thickness (mm) : 100=1.00mm, 010=0.10mm, 001=0.01mm
- ③ Frequency : required to have working frequency ranges
- ④ Width (mm)
- ⑤ Length (mm)
- ⑥ Tape Type : A(100 μ m), A1(50 μ m), A2(30 μ m), A3(20 μ m),C(none)
- ⑦ None : Rectangular type, S : Shape type

[For Example]

IDCI-150-8G-210-300-A-S

- ▶ Thickness : 1.50mm
- ▶ Frequency : 8GHz
- ▶ Width : 210mm
- ▶ Length : 300mm
- ▶ Tape Type : A
- ▶ S : Shape type

IDCIM series - Double and Wide band type EMI Absorber

Features

- IDCIM Series is a multi-layered absorber composed of at least two sheets of soft magnetic material.
- In broadband, narrowband and double wide band, reflection reduction is occurred.
- The application frequency range; C(4 ~ 8GHz), X(8 ~ 12GHz), Ka, K band.
- It is possible to add thermal conductive property on IDCIM series.

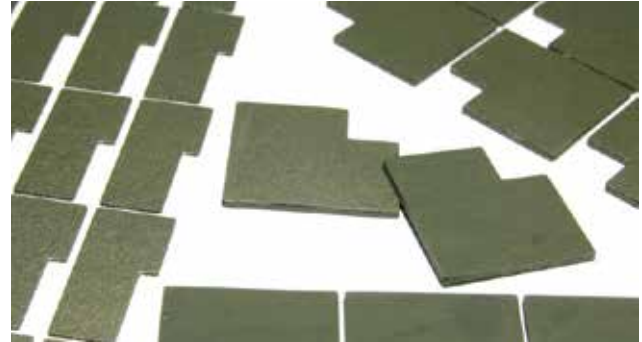

Structure

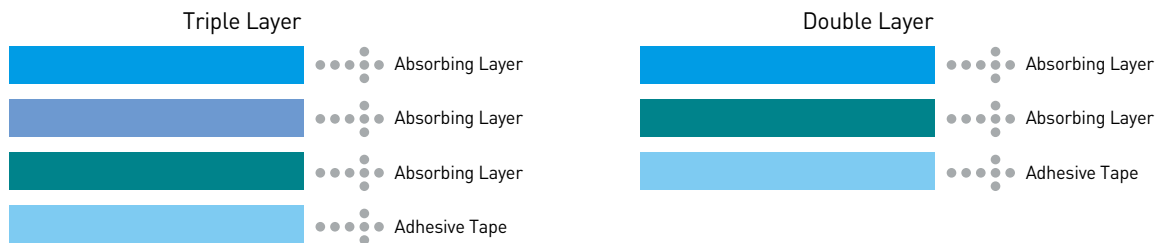

Specifications

Item	IDCIM series						
	IDCIM - 075	IDCIM - 100	IDCIM - 150	IDCIM - 200	IDCIM - 300	IDCIM - 400	IDCIM - 500
Thickness (mm)	0.75 (±0.05)	1.00 (±0.10)	1.50 (±0.20)	2.00 (±0.20)	3.00 (±0.30)	4.00 (±0.40)	5.00 (±0.50)
Frequency Range	6GHz~20GHz			500MHz~6GHz			
Hardness (Shore A)	80 ± 5 (for Standard type)						
Service Temp. (°C)	-30 ~ 150						
Standard Size	210mm × 300mm						
Flammability	Non Flammable						
Surface Resistance (Ω)	Min 1.0 × 10 ⁶						
Density (g/cm ³)	3.6 ± 0.5 (for Standard type)						

How to Order

P/N : IDCIM - AAA - BBB - CCC - DDD - EEE - FFF

① ② ③ ④ ⑤ ⑥ ⑦

- ① Serial Number
- ② Thickness (mm) : 100=1.00mm, 010=0.10mm, 001=0.01mm
- ③ Frequency : required to have working frequency ranges
- ④ Width (mm)
- ⑤ Length (mm)
- ⑥ Tape Type : A(100 μ m), A1(50 μ m), A2(30 μ m), A3(20 μ m), C(none)
- ⑦ None : Rectangular type, S : Shape type

[For Example]

IDCIM-300-6G-210-300-A-S

- ▶ Thickness : 3.00mm
- ▶ Frequency : 6GHz
- ▶ Width : 210mm
- ▶ Length : 300mm
- ▶ Tape Type : A
- ▶ S : Shape type

Thermal Interface Material

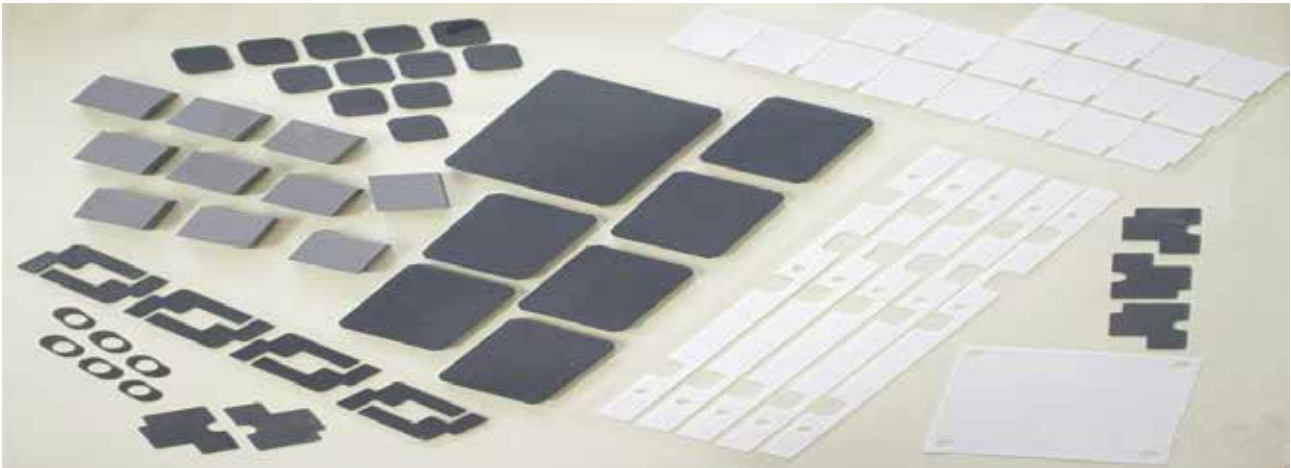

Gel type

- IDHT-G series
- IDHT-L series

Sheet type

- IDHT-S series

Grease type

- IDTG series



● Why is Heat Transfer important?

In these days, a lot of electronic devices demand very high levels of thermal management. The objective of all thermal control programs in electronic packaging is the efficient removal of heat from device junctions to the ambient environment, and packaging of portable electronics is slim, which means that components are more closely packed together, so the amount of heat is increased. Clock speed of processor and overall power density are increasing, which means that more heat must be dissipated per volume of electronic equipment than ever before.

Achieving this goal requires a thorough understanding of heat transfer process : key physical properties affect and knowledge of interface material available.

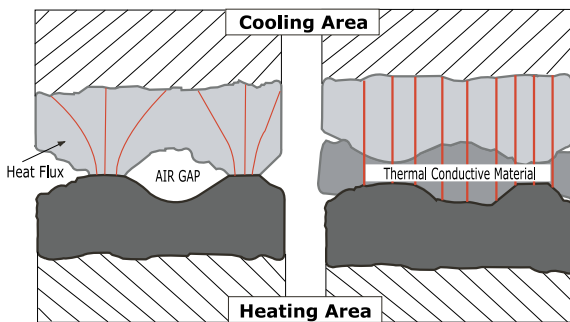
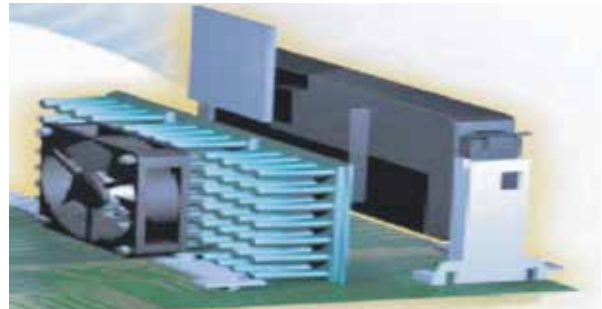

Attaching heat sink to a semiconductor package surface requires two commercial grade surfaces to be brought into intimate contact. These surfaces are usually characterized by a microscopic surface, roughness, superimpose, & macroscopic non-planarity that can give the surfaces a concave, convex or twist shape. When two such surfaces are joined, contact occurs only at the high points. The low points form air-filled voids. Typical contact area can consist of more than 90 percent air voids, which represents a significant resistance to heat flow.

IDT Series is used to eliminate these interstitial air gaps from the interfaces.

Because the material has greater thermal conductivity than through air it replaces, the resistance across the joints decreases, while the component junction temperature will be reduced.

IDT Series is DI materials's thermal management product made of high thermal conductivity and superior flame-retardant which specified organic properties.

If you focus to maximizing the heat transfer,

IDT Series meets the specification : UL approval for 94V-0 flame class.

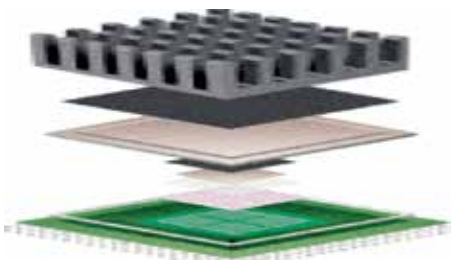
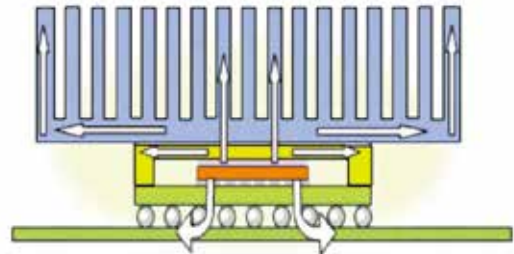

● Properties of Thermal Interface Materials

Thermal impedance is the measure of the total resistance to the flow of heat from a hot surface through an interface material into a cold surface. It is measured according to the ASTM D5470 test method. Although the current version of this method is specific to high durometer insulating pad materials tested at high clamping forces, the method has been successfully adapted for use with low durometer materials as well as fluid compounds.

IDHT-G series - Gel type TIM

Features

- IDHT G series is very soft, freestanding gap filler that is more compressible than any other gap filler.
- IDHT-G series has not only good thermal conductivity of 1.5 ~ 12.0W/m-K but also high compressibility, which leads to low thermal impedance.
- IDHT-G series is inherently sticky, so not necessary to use additional adhesive coating which deteriorates thermal performance.
- IDHT-G series is electrically insulated and stable from -40°C to 200°C.



Applications

- Cooling Components to the Chassis or Frame
- High Speed Mass Storage Drives
- RDRAM Modules
- Micro Processors, Memory Chips and Chipsets
- Thermal Solution for Heat Pipe
- Automotive Engine Control Units
- Telecommunication Hardwares

Specifications

Content	Item	IDHT G Series						
		(S)-G1540	(S)-G1550	(S)-D1550	(S)-G1850	G1560	G1	G3030
Color		Gray, Pink, Sky blue, etc (Customization)						
Thickness (mm)		0.5~20.0	0.5~20.0	0.5~20.0	0.5~20.0	0.5~10.0	0.5~10.0	0.5~10.0
Thermal Conductivity (W/m-K)		1.5	1.5	1.5	1.8	1.5	2.0	3.0
Hardness (Shore 00)		40	50	50	50	60	40	30
Specific Gravity		2.6	2.57	2.57	2.57	1.8	2.5	2.86
Volume Resistivity (Ω-cm)		-	1.0×10 ¹⁴	1.0×10 ¹⁴	1.0×10 ¹⁴	1.0×10 ¹¹	1.0×10 ¹⁴	1.0×10 ¹¹
Voltage Breakdown (kV)		-	-	-	-	5.1	>6	>6
Service Temp. (°C)		-60 ~ 200	-60 ~ 200	-60 ~ 200	-60 ~ 200	-40 ~ 200	-40 ~ 200	-40 ~ 200

Content	Item	IDHT G Series						
		G3050	G4050	G5050	G6050	G8070	GH1060	GH1250
Color		Gray, Pink, Sky blue, etc (Customization)						
Thickness (mm)		0.5~10.0	0.5~10.0	0.5~10.0	0.5~10.0	0.5~5.0	0.5~5.0	0.5~5.0
Thermal Conductivity (W/m-K)		3.0	4.0	5.0	6.0	8.0	10.0	12.0
Hardness (Shore 00)		50	50	50	50	70	60	50
Specific Gravity		2.86	2.97	3.0	3.05	3.13	3.05	3.0
Volume Resistivity (Ω-cm)		1.0×10 ¹¹	1.0×10 ¹¹	1.0×10 ¹¹	1.0×10 ¹¹	1.0×10 ¹¹	1.0×10 ¹¹	1.0×10 ¹¹
Voltage Breakdown (kV)		>6	-	-	-	-	-	-
Service Temp. (°C)		-40 ~ 200	-40 ~ 200	-40 ~ 200	-40 ~ 200	-40 ~ 200	-40 ~ 150	-40 ~ 150

IDHT-L Series - Less Oil Bleeding type TIM

Features

- IDHT L series is very soft, freestanding gap filler that is more compressible than any other gap filler.
- IDHT-L series has not only good thermal conductivity of 1.5~5.0W/m·K but also high compressibility, which leads to low thermal impedance.
- IDHT-L series is inherently sticky, so not necessary to use additional adhesive coating which deteriorates thermal performance.
- IDHT-L series is electrically insulated and stable from -40°C to 200°C .
- IDHT-L series Has Less Oil Bleeding also Excellent Flame retardancy and insulation

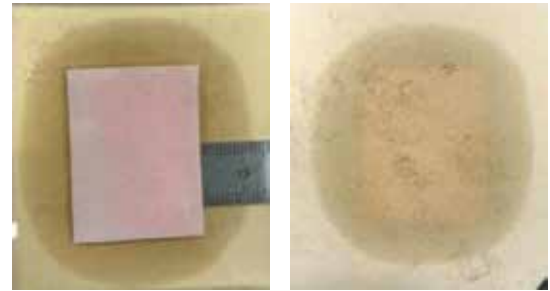

Gap Pad



IDHT-L Type

Specifications

Content	Item	IDHT L Series			
		L1560BV	L3050BV	L4060BV	L5060BV
Color		Gray, Pink, Sky blue, etc (Customization)			
Thickness (mm)		0.5~10.0	0.5~10.0	0.5~5.0	0.5~5.0
Thermal Conductivity (W/m·K)		1.5	3.0	4.0	5.0
Hardness (Shore 00)		60	50	60	60
Specific Gravity		2.86	2.86	2.97	2.97
Volume Resistivity ($\Omega\cdot\text{cm}$)		1.0×10^{11}	1.0×10^{11}	1.0×10^{11}	1.0×10^{11}
Voltage Breakdown (kV)		>6	>6	>6	>6
Service Temp. ($^{\circ}\text{C}$)		-40 ~ 200	-40 ~ 200	-40 ~ 200	-40 ~ 200
Oil Bleeding(mm)*		0.1 ~ 2.0	0.1 ~ 2.0	0.1 ~ 2.0	0.1 ~ 2.0

* IDHT L Series has Over the 10% less Oil bleeding then Gap Pad(By D.I.M Method)

IDHT-G,L series

Selection Guide

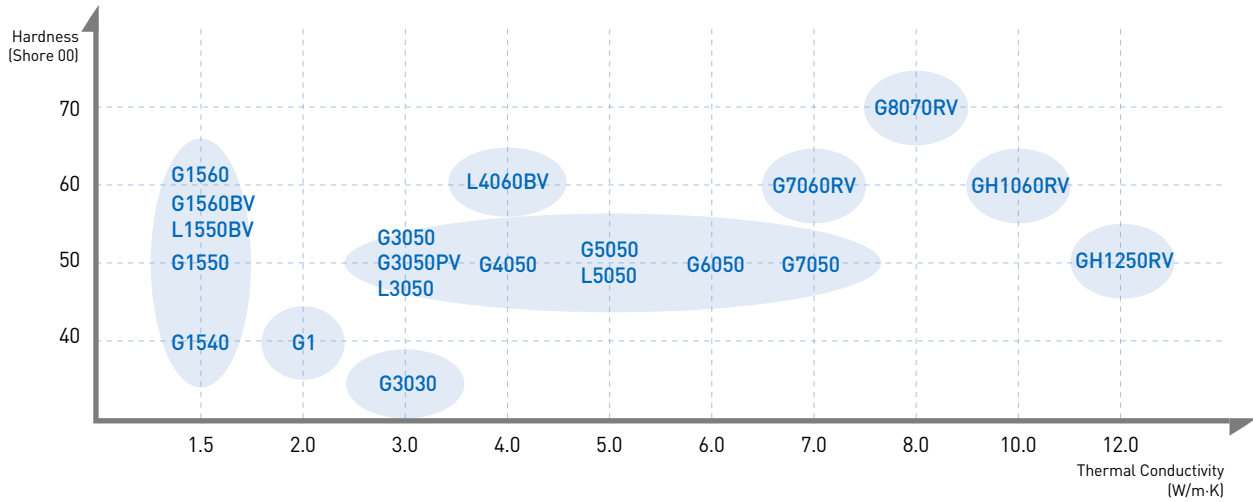

How to Order

P/N : IDHT - AAA - G - BBB - CCC - DDD - EEE - FFF - GGG - HHH

① ② ③ ④ ⑤ ⑥ ⑦ ⑧ ⑨ ⑩

- ① Heat Transfer : none or (S)
- ② Thickness (mm)
- ③ Type (G : Gel type, L : Low Oil Bleeding, GH: Gel type / Over 10W)
- ④ -1 Thermal conductivity(W/m.K)
- ④ -2 Hardness(Shore 00 ~ Shore A)
- ④ -Color(Gray,Pink,Blue,Red)
- ⑤ Width (mm)
- ⑥ Length (mm)
- ⑦ Tape type : A(100 μ m), A1(50 μ m), C(none)
- ⑧ Tacky Type : O(One Side Tacky), B(Both Side Tacky)
- ⑨ None : Rectangular type, S : Shape type



[For Example]

IDHT(S)-0.5-G1550-210-300-C

- ▶ Thickness : 0.5mm
- ▶ Thermal Conductivity : 1.5W/m.K
- ▶ Hardness : 50 Shore 00
- ▶ Color : Gray
- ▶ Width : 210mm
- ▶ Length : 300mm
- ▶ Tape Type : C(none)
- ▶ Rectangular type

[For Example]

IDHT-0.5-G1560BV-210-300-A-S

- ▶ Thickness : 0.5mm
- ▶ Thermal Conductivity : 1.5W/m.K
- ▶ Hardness : 60 Shore 00
- ▶ Color : Blue
- ▶ Width : 210mm
- ▶ Length : 300mm
- ▶ Tape Type : A(100 μ m)
- ▶ Shape type

IDHT-S series - Sheet type TIM

Features

- IDHT-S1 has high thermal conductivity of 4.0W/m-K to produce low thermal impedance.
- IDHT-S1 is electrically insulating, stable from -30°C to 200°C.
- Available in various thickness from 0.1mm to 0.35mm
- IDHT-S1 does not require reinforcement.
- Not only the lowest thermal resistance but the highest dielectric strength are the distinctive characteristics of IDHT-S1.

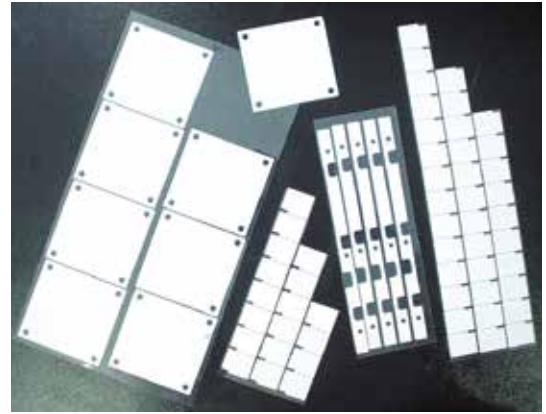

Applications

- CPU / Heat Sink
- Power Devices, Voltage Regulators / Heat Sink
- PCB / Heat Sink
- PCB / Case or Chassis
- CD ROM drive / Case
- PCB / PCB

Specifications

Content	IDHT-S1
Color	White
Thickness (mm)	0.1 ~ 0.35
Hardness (Shore A)	60
Specific Gravity	2.7
Thermal Conductivity (W/m·K)	4.0
Volume Resistivity (Ω·cm)	1.0×10^{11}
Voltage Breakdown (kV)	5.1
Tensile Strength (MPa)	15
Service Temp. (°C)	-30~200

How to Order

P/N : IDHT - AAA - S 1 - BBB - CCC - DDD - EEE

① ② ③ ④ ⑤ ⑥ ⑦

- ① Heat Transfer
- ② Thickness (mm)
- ③ Type (S1 : sheet type)
- ④ Width (mm)
- ⑤ Length (mm)
- ⑥ Tape type : A(100 μ m), A1(50 μ m), C(none)
- ⑦ None : Rectangular type, S : Shape type

[For Example]

IDHT-0.1-S1-210-300-A-S

- ▶ Thickness : 0.1mm
- ▶ Type : S1
- ▶ Width : 210mm
- ▶ Length : 300mm
- ▶ Tape Type : A(100 μ m)
- ▶ Shape type

IDTG series - Grease type TIM

Features

- Applied to the heating part, heat dissipation in the vertical direction to prevent parts damage due to high heat.
- Used as liquid product, dispensing method.
- Easy to apply to structures with bending, irregularities, etc.
- Diverse products by thermal conductivity (~ 5W / mK) performance



Specifications

Content	Item	IDTG N Series (1.0~5.0 W/m·K)				
		N010	N020	N030	N040	N050
One or Two-part		One				
Color		Gray, Pink, White, Sky blue				
Thermal Conductivity (W/m·K)		1.0	2.0	3.0	4.0	5.0
Cure Condition (°C)		Non-cure				
Breakdown Voltage (kV/mm)		> 11				
Volume Resistivity (Ω·cm)		1.0×10 ¹¹	1.0×10 ¹¹	1.0×10 ¹¹	1.0×10 ¹¹	1.0×10 ¹¹
Service Temp. (°C)		-30 ~ 200	-30 ~ 200	-30 ~ 200	-30 ~ 200	-30 ~ 200

Content	Item	IDTG R Series (1.0~5.0 W/m·K)				
		R01060	R2040	RR3560	R4060	R5070
One or Two-part		Two part (A type, B type)				
Color		Gray, Pink, White, Sky blue				
Thermal Conductivity (W/m·K)		1.0	2.0	3.0	4.0	5.0
Cure Condition (°C)		24°C × 24hr (or 130°C × 15min)				
Breakdown Voltage (kV/mm)		> 11				
Volume Resistivity (Ω·cm)		1.0×10 ¹¹	1.0×10 ¹¹	1.0×10 ¹¹	1.0×10 ¹¹	1.0×10 ¹¹
Service Temp. (°C)		-30 ~ 200	-30 ~ 200	-30 ~ 200	-30 ~ 200	-30 ~ 200

How to Order

P/N : IDTG - AAA - BBB

① ② ③

- ① Heat Transfer
- ② Type : N(None Curing Type), R(Curing Type)
- ③ Thermal Conductivity

[For Example]

IDTG-N050

- ▶ Heat Transfer : Grease
- ▶ Type : None Curing
- ▶ Thermal Conductivity : 5W

Silicone Foam

Product Description

- Closed cell structure with air pore-like shape
- Use of shock absorbers as repulsive elastic energy
- Flame retardancy, thermal stability of UL 94 V-0

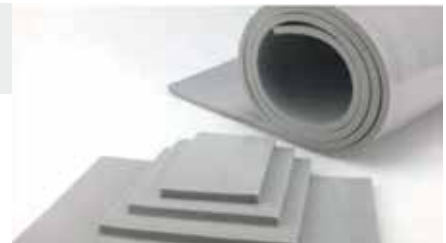

Applications

- Electric vehicle battery
 - It is located between cells and protects the cell and maintains the rigidity of the module structure by absorbing shock when the cell swelling occurs
 - No harmful gases generated during thermal runaway in electric vehicle batteries
 - Delaying thermal runaway

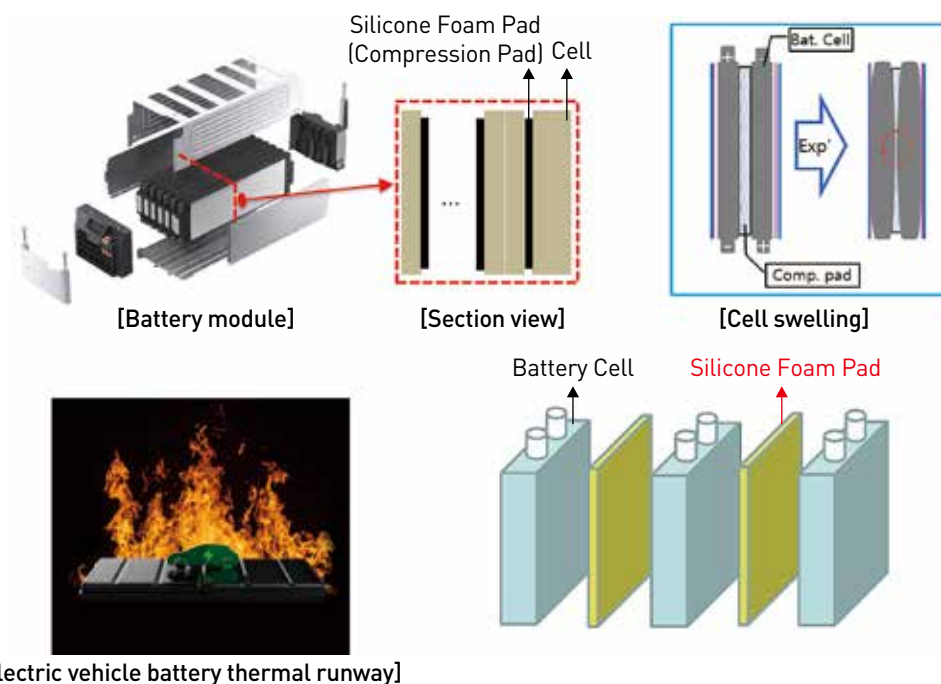

- For Cushioning & Absorbing shock in Gasket.
- Using in Electrical parts & Transportation as a vibration absorber
- Nonflammable / Insulating
- TV, Smart Phone, Notebook, Monitor

Silicone Foam

Structure



No.	Item	Materials	Color	Thickness [mm]
①	Silicone Foam	Silicone + Filler	All	0.5~10
②	Support Layer (option)	PET or Tape(Single / Double)	Clear	0.05~0.15

Specifications

Contents	Unit	IDSF Series	IDSF(TP ¹) Series	Test Method
Structure	/			/
Color	/	Black / Gray / White	Black / Gray / White	Visual
Thickness	mm	0.5~10	0.5~10	Thickness gauge
Density	g/cm ³	0.2~0.6	0.6~0.8	ASTM D1058
25% C.F.D. (Compression Force Deflection)	kgf/cm ²	0.1~0.4	1.2~1.6	ASTM D1058
Compression Set	%	< 10	< 10	ASTM D1056, 100°C, 22hr, 50%
Tensile Strength	Mpa	≥ 0.2	≥ 0.2	ASTM D 412
Elongation at Break	%	≥ 80	≥ 80	ASTM D 412
Water Absorption	%	< 10	< 10	ASTM D 1056, Vacuum 85kPa
Electrical Performance				
Dielectric Strength	kV/mm	≥ 3.0	≥ 3.0	GB/T 1695-2005
Volume Resistivity	Ω·cm	≥ 1.0 × 10 ¹⁴	≥ 1.0 × 10 ¹⁴	GB/T 1695-2008
Thermal Performance				
Thermal Conductivity	W/(m·K)	< 0.1	< 0.1	ASTM C 518
Operating Temperature Range	°C	-55 ~ 200	-55 ~ 200	SAE J 2238
Flame Retardant Properties				
Flame Retardant	/	V-0	V-0	UL 94

1) TP : Thermal Propagation, 2) TPP : Thermal Propagation Protection

Conductive Elastomer

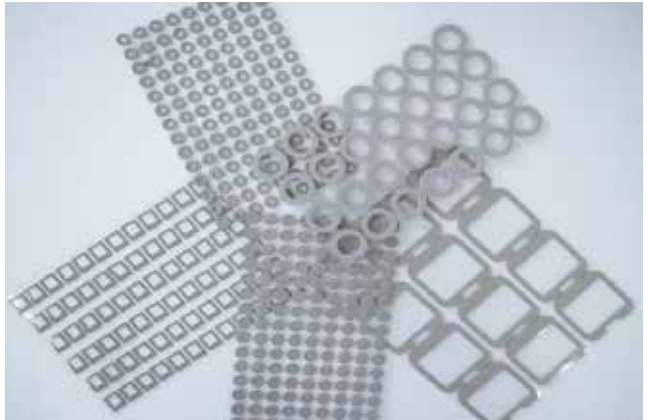
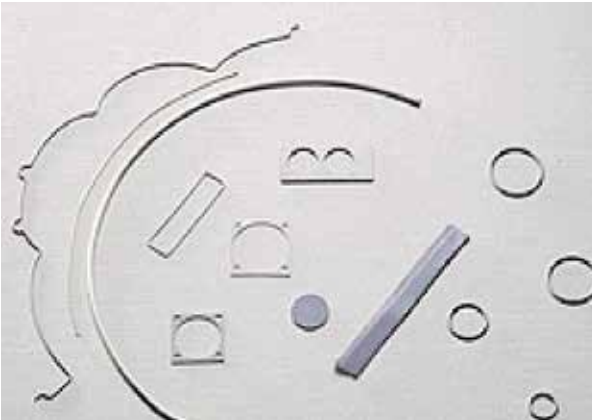

Conductive Silicone

- Mold Type
- Extrusion Type

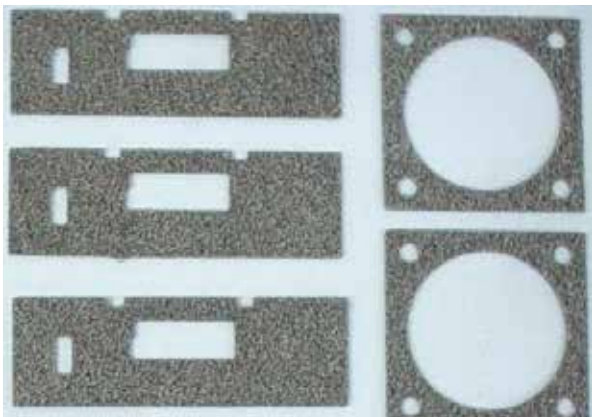
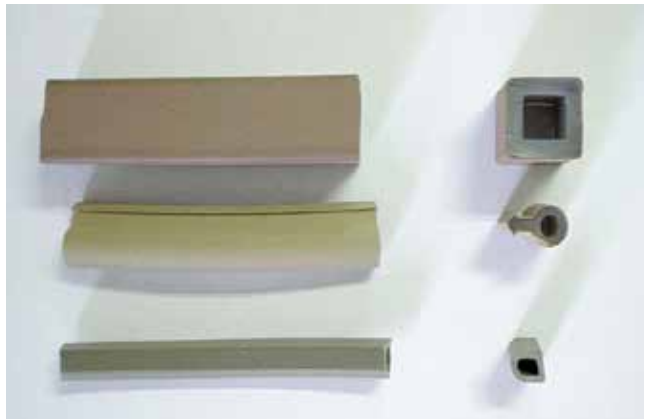

Conductive Silicone

Introduction

The Conductive Silicone is filled with metal filler. It provides high electric conductivity, shielding and moisture sealing. This item is manufactured in sheets, molded type, extrusion type and film type by request.



Applications

This Gasket can be used in applications where it is needed for excellent shielding, high conductivity and long term stability. For example, telecommunication, information technology, medical and industrial electronic equipment markets are major applicable fields.

Specifications

Electrically Conductive Silicone					
		Conductive Filler	SC	NC	C
		Binder	Silicone	Silicone	Silicone
Electrical Properties	Volume Resistivity ($\Omega\cdot\text{cm}$)		0.02	0.10	5.0
	Shielding Effectiveness (dB, ASTM D 4935)		More than Avg. 60	More than Avg. 40	More than Avg. 40
Physical Properties	Specific Gravity		3.7 (± 0.3)	2.0 (± 0.3)	2.0 (± 0.3)
	Hardness (Shore A)		65 (± 5)	60 (± 5)	70 (± 10)
	Tensile Strength (kgf/cm^2)		30 (430psi)	20 (285psi)	20 (285psi)
	Tear Strength (kN/m)		6	6	6
	Elongation (%)		200	200	180
	Service Temp. ($^{\circ}\text{C}$)		- 50 ~ 120	- 50 ~ 120	- 40 ~ 200
Thermal Conductivity	Vertical (W/m-K)		1.1	0.8	0.8
	Horizontal (W/m-k)		1.3	1.6	1.6

* The values in this table are properties of only conductive silicone.

- * Material
 - SC : Silver coated Copper
 - NC : Nickel coated Graphite
 - C : Carbon

Quality Performance (SE)

● Conductive Silicone

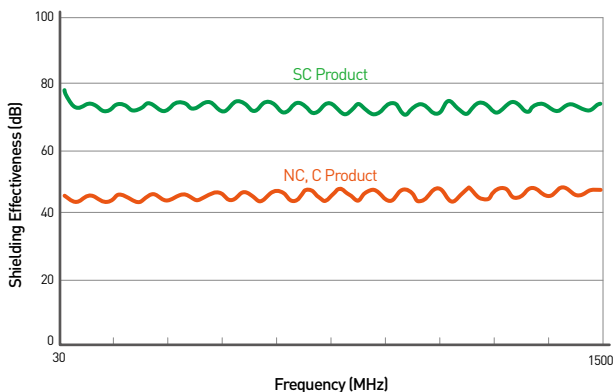

● Conductive Silicone with Conductive mesh tape

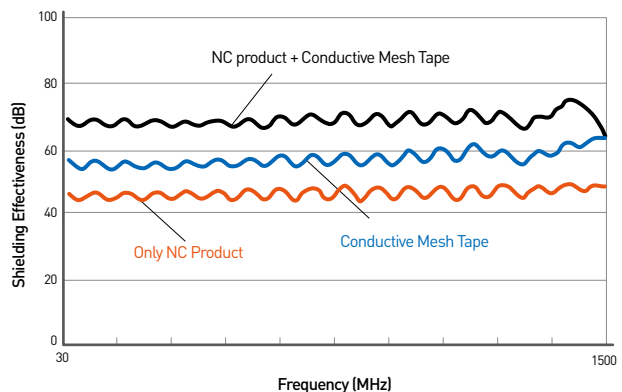

Mold Type

● Sheet Gasket

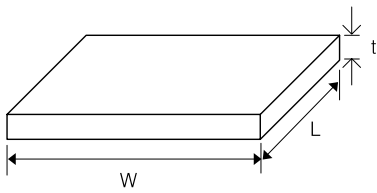

P/N : IDSG - AAA - BBB - CCC - DDD - EEE - FFF

- ①
- ②
- ③
- ④
- ⑤
- ⑥
- ⑦

- ① Serial Number
- ② Thickness : mm
- ③ Material : SC, NC, C
- ④ Outer Size (mm) or Width (mm) - sheet type
- ⑤ Inner Size (mm) or Length (mm) - sheet type
- ⑥ Tape (sheet type) : C (None Adhesive), D (Silicone Mesh tape)
- ⑦ S : Refer to Drawing

● Sheet Gasket

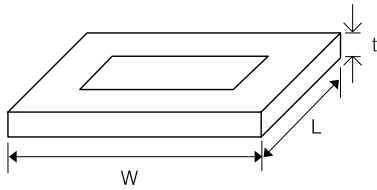

P/N : IDSSG - AAA - BBB - CCC - DDD - EEE - FFF

- ①
- ②
- ③
- ④
- ⑤
- ⑥
- ⑦

- ① Serial Number
- ② Thickness : mm
- ③ Material : SC, NC, C
- ④ Outer Size (mm) or Width (mm) - sheet type
- ⑤ Inner Size (mm) or Length (mm) - sheet type
- ⑥ Tape (sheet type) : C (None Adhesive), D (Silicone Mesh tape)
- ⑦ S : Refer to Drawing

● O-Ring Gasket 1

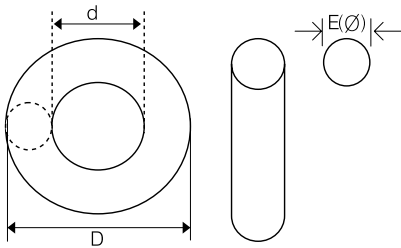

P/N : IDOG - AAA - BBB - CCC - DDD - EEE

- ①
- ②
- ③
- ④
- ⑤
- ⑥

- ① Serial Number
- ② Thickness (mm) or Diameter (∅)
- ③ Material : SC, NC, C
- ④ Outer Size (mm)
- ⑤ Inner Size (mm)
- ⑥ S : Refer to Drawing

● O-Ring Gasket 2

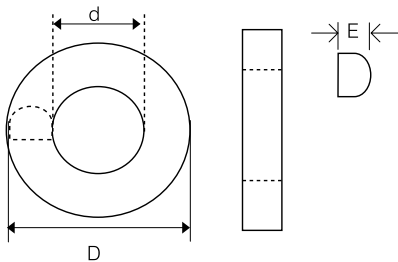

P/N : IDDG - AAA - BBB - CCC - DDD - EEE

- ①
- ②
- ③
- ④
- ⑤
- ⑥

- ① Serial Number
- ② Thickness (mm) or Diameter (∅)
- ③ Material : SC, NC, C
- ④ Outer Size (mm)
- ⑤ Inner Size (mm)
- ⑥ S : Refer to Drawing

● Washer Gasket

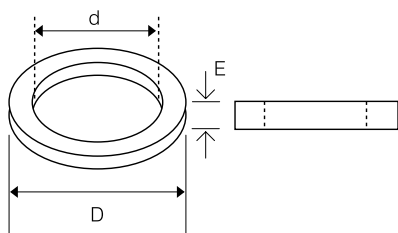

P/N : IDWG - AAA - BBB - CCC - DDD - EEE - FFF

- ①
- ②
- ③
- ④
- ⑤
- ⑥
- ⑦

- ① Serial Number
- ② Thickness (mm)
- ③ Material : SC, NC, C
- ④ Outer Size (mm) or Width (mm) - sheet type
- ⑤ Inner Size (mm) or Length (mm) - sheet type
- ⑥ Tape (sheet type) : C (None Adhesive), D (Silicone Mesh tape)
- ⑦ S : Refer to Drawing

● Connector Gasket

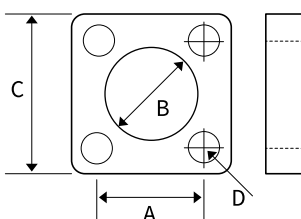

P/N : IDCG - AAA - BBB - CCC - DDD - EEE - FFF

- ①
- ②
- ③
- ④
- ⑤
- ⑥
- ⑦

- ① Serial Number
- ② Thickness : mm
- ③ Material : SC, NC, C
- ④ Outer Size (mm) or Width (mm) - sheet type
- ⑤ Inner Size (mm) or Length (mm) - sheet type
- ⑥ Tape (sheet type) : C (None Adhesive), D (Silicone Mesh tape)
- ⑦ S : Refer to Drawing

Extrusion Type

● 0-Strips

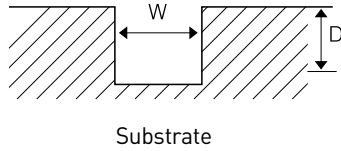
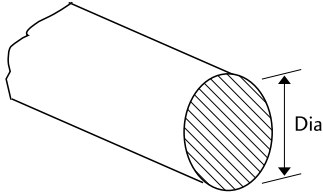

P/N : IDCSO - AAA - BBB

① ② ③

- ① Serial Number
- ② Size (mm)
- ③ Material : SC, NC

Unit : mm

P/N	Nominal Diameter	Recommended Groove Dimensions	
		W	D
IDCSO-071	0.71	0.80	0.59
IDCSO-081	0.81	0.91	0.66
IDCSO-102	1.02	1.14	0.81
IDCSO-122	1.22	1.35	0.97
IDCSO-135	1.35	1.50	1.07
IDCSO-140	1.40	1.52	1.12
IDCSO-152	1.52	1.60	1.20
IDCSO-157	1.57	1.68	1.27
IDCSO-170	1.70	1.85	1.38
IDCSO-178	1.78	1.93	1.42
IDCSO-185	1.85	1.96	1.46
IDCSO-188	1.88	1.98	1.50
IDCSO-198	1.98	2.13	1.60
IDCSO-203	2.03	2.18	1.65
IDCSO-216	2.16	2.31	1.75
IDCSO-229	2.29	2.45	1.85
IDCSO-236	2.36	2.52	1.89
IDCSO-254	2.54	2.71	2.02
IDCSO-262	2.62	2.79	2.08
IDCSO-284	2.84	3.02	2.26
IDCSO-300	3.00	3.18	2.39
IDCSO-302	3.02	3.20	2.41
IDCSO-318	3.18	3.38	2.54
IDCSO-320	3.20	3.40	2.57
IDCSO-330	3.30	3.48	2.64
IDCSO-340	3.40	3.59	2.72
IDCSO-353	3.53	3.73	2.82
IDCSO-373	3.73	3.96	2.96
IDCSO-396	3.96	4.18	3.10
IDCSO-401	4.01	4.27	3.17
IDCSO-432	4.32	4.61	3.42
IDCSO-478	4.78	5.08	3.81
IDCSO-495	4.95	5.29	3.92
IDCSO-711	7.11	7.35	6.05

01
02
03
04 _ Conductive Elastomer
05
06
07
08
09
10
11

Extrusion Type

● D-Strips

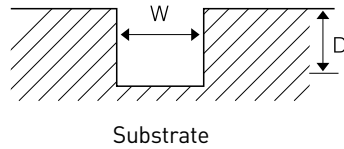
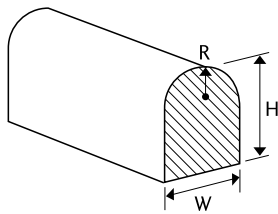

P/N : IDCSD - AAA - BBB

① ② ③

- ① Serial Number
- ② Size (mm)
- ③ Material : SC, NC

Unit : mm

P/N	Nominal Dimension		
	W	H	R
IDCSD-140	1.62	1.40	0.81
IDCSD-163	1.40	1.63	0.70
IDCSD-173	1.57	1.73	0.79
IDCSD-178	2.03	1.78	1.02
IDCSD-198	2.39	1.98	1.19
IDCSD-216	1.57	2.16	0.78
IDCSD-226	1.98	2.26	0.99
IDCSD-239	2.39	2.39	1.19
IDCSD-241	1.78	2.41	0.89
IDCSD-279	3.81	2.79	1.91
IDCSD-292	2.60	2.92	1.30
IDCSD-345	3.15	3.45	1.55
IDCSD-396	3.96	3.96	1.98

Extrusion Type

● O-Strips Tubing

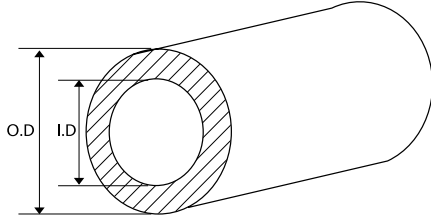

P/N : IDCS00 - AAA - BBB

① ② ③

- ① Serial Number
- ② Size (mm)
- ③ Material : SC, NC

Unit : mm

P/N	Nominal Dimension	
	O.D	I.D
IDCS00-152	1.52	0.51
IDCS00-185	1.85	0.51
IDCS00-198	1.98	0.71
IDCS00-229	2.29	1.02
IDCS00-262	2.62	1.02
IDCS00-279	2.79	1.14
IDCS00-300	3.00	1.40

P/N	Nominal Dimension	
	O.D	I.D
IDCS00-318	3.18	1.14
IDCS00-320	3.20	1.14
IDCS00-330	3.30	1.14
IDCS00-368	3.68	1.50
IDCS00-396	3.96	1.27
IDCS00-400	4.00	1.30
IDCS00-457	4.57	2.00

● D-Strips Tubing

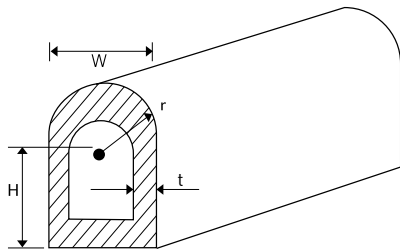

P/N : IDCSD0 - AAA - BBB

① ② ③

- ① Serial Number
- ② Size (mm)
- ③ Material : SC, NC

Unit : mm

P/N	Nominal Dimension			
	W	H	r	t
IDCSD0-396	3.96	1.98	1.98	1.14

● Hollow Rectangular Strips

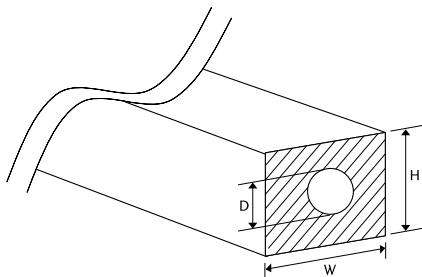

P/N : IDCSRO - AAA - BBB

① ② ③

- ① Serial Number
- ② Size (mm)
- ③ Material : SC, NC

Unit : mm

P/N	Nominal Dimension		
	W	H	D
IDCSRO-953	9.53	9.53	4.78

Conductive Paste

Conductive Silicone Sealant

- Dispensing Gasket



Conductive Paste

- IDP series



Conductive Silicone Sealant -for EMI dispensing gasket

Introduction

DI materials Conductive Silicone Sealant (or Foam-in-place) is an automated system for dispensing gasket EMI shielding. Dispensing gasket compounds are Room Temperature Vulcanizing (RTV) elastomers, filled with conductive particles. Our product develop to achieve optimum EMI shielding performance the component surface on which the gasket is to be deposited must be highly conductive as low contact resistance is required between the two. And designed to support low closure force and is compatible with plastic, metal, and plated or chromate finished substrates.

Features

- RTV (Room Temperature Vulcanizing) conductive sealant
- Electrical conductivity as low as .001ohm-cm
- High shielding and conductivity critical for inter-compartmental shielding.
- Good adhesion properties on various substrates
 - Silver or/and Silver coated Copper filled paint
 - Magnesium and other casting alloys
 - Nickel or/and Copper plating



Applications

- Mobile Phones, Especially DMB (Digital Multimedia Broadcasting) Phones
- Computer Peripherals
- PDA (Personal Digital Assistants)
- Military Equipment
- Material of Conductive Joint, Bonding & Packing

Curing Conditions

It takes maximum 24 hours for complete curing at the room temperature.

However, curing time will be reduced to about 8 hours at the high temperature (30~50°C) and high humidity (50~70%).

Handling Cautions

For it reacts to the moisture and oxygenic atmosphere, a high attention should be paid to handling this product and the handling cautions are ;

1. Curing time will be dependent on humidity and temperature.
2. Prolonged storage at room temperature should be avoided.
3. Prolonged exposure to high temperature (above 30°C) should be prohibited.
4. The adhesion strength will be changed according to the material of substrate and / or coating.
5. Shelf life is 4 weeks after manufacturing data at storage temperature (1~10°C).

Specifications

Properties		Unit	E
Material Description	Base Material	-	RTV Silicone
	Filler	-	Ag/Cu
	Color	-	Beige
	Cure	-	Moisture
As Supplied	Surface dry / Tack- Free Time	Min. (Ø=0.5mm)	Min. 1'30"
	Cure Time ¹⁾	Hr. (Ø=0.5mm)	12~24
	Operating Temp.	°C	-50 ~ 120
	Storage Temp.	°C	1 ~ 10
	Shelf Life (Cartridge)	Months	3
	Shelf Life (Barrel)	Weeks	4
Cured Characteristics	Hardness	Shore A	57 (±5)
	Volume Resistivity ²⁾	Ω-cm	Max. 0.001
	Specific Gravity	-	2.5 (±0.5)
	Adhesion on PCB	g	Min. 400

Note : 1) Time for complete curing is determined under given conditions.

Recommended curing condition : 20°C. 50% RH

2) Volume resistivity (MIL-G-83528)

How to Order

P/N : ID - CSS - AAA - BBB

① ② ③

① Serial Number

② Type : E

③ Packing type

None : Syringe type

CT : Cartridge type

Method of Dispensing Gasket

Features

DI materials's Dispensing Gasket newly upgraded gives excellent EMI Shielding effect, good electric grounding, waterproof and general environment sealing in many applications.

This Dispensing Gasket is manufactured by Auto-Dispensing machine attached to CNC-Robot (X-Y-Z axis).

This Gasket is providing the customers' process that is suitable for cost-down in mass production, and DI materials can provide the precision CNC-Robot with fixture and the 1-Part Conductive Silicone, which is made of silver and silicone, on a full package sales, including knowledge.



The Variable Affecting the Quality of Dispensing Gaskets

Conditions

- Constant pressure applied
- Material of substrate
- Moving speed
- Material of sealants
- Surface of substrates
- Size of nozzle

Moving Speed is reasonable Good Result	Moving Speed is too fast Poor Result	Moving Speed is too slow Poor Result

Structure and Design

Shape

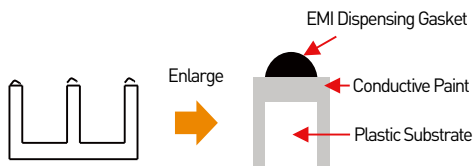

Application

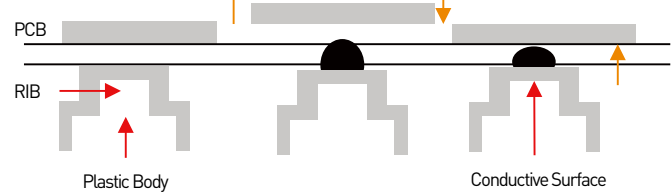

Design of Rib and Gasket

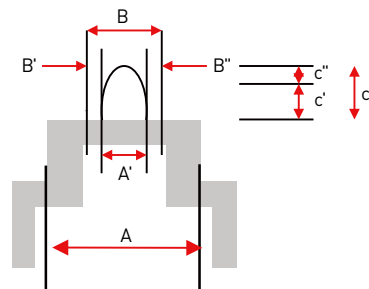

- 10-20% pressing of gasket is recommended for ideal EMI Shielding Effect.
- B' is dependent on desired cross section of gasket when it is pressed.
- If C'=0.3, C=0.38-0.45 and If C'=0.4, C=0.48-0.52.

(Unit: mm)

Division	Specification
A: Rib width	Min 0.5
A': Gasket width before pressing	Min 0.4 (Max 80% of A)
B: Gasket width after pressing	Max A
B'': Gasket width after pressing	Max 2B' + B < A
C: Gasket height before pressing	Max A', Min. 50% of A'
C': Gasket height after pressing	Min 90% of C
C'': Gasket height before pressing	C'' = Min 10% of C
- Gasket height after pressing	

01
02
03
04
05 _ Conductive Paste
06
07
08
09
10
11

Conductive Paste

Introduction

DI materials has developed conductive paste that is designed to provide EMI/RFI shielding on the insulation substrates.

DI materials's conductive paste is composed of high electric conductive silver filler.

This product is formulated in low VOC that can prevent sensitive substrates such as polycarbonate (PC) to solvent.



Features

- Excellent Shielding Performance
- Excellent Adhesive Characteristics to most Plastic Substrate (especially PC and PC alloys)
- Low Resistivity at thin Film Build
- Excellent Film Cohesion
- Sprayable and Brushable in Applications

Applications

- Mobile Phones
- RF Amplifier Modules
- Automobile Applications
- Medical Equipments
- Test Instruments, Monitors
- Industrial / Auto Control System
- Antennas
- Computer Peripherals
- Military Equipments

Specifications

Content		IDP-01S
Properties	Resin	Polyurethane
	Filler	Silver
	System	Solvent-based
	Solid Content	46.0 ± 1.5 wt%
	Specific Gravity	1.40 ± 0.05
	Viscosity	14.0 ± 2.0 sec
Characteristics	Recommended Thickness	12.5 μ m (Dry film)
	Volume Resistivity	Max. 10 \times 10 ⁵ Ω -cm
	Shielding Effectiveness	More than Avg. 70 [30MHz~1.5GHz]
	Diluent	EtOH, Acetone (Especially, EtOH : paste=1 : 1 at volume ratio is recommended)
	Drying Time	15 min at 60°C
	Shelf Life (unopened)	6 months

Test Method

Surface Resistivity	Point-to-point method
SE	ASTM D4935
Viscosity	#2 EZ Zahn Cup (EtOH : paste=1 : 1 at volume ratio)

Quality Performance (SE)

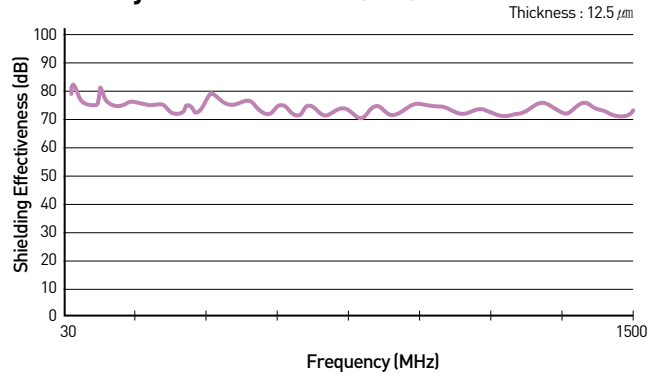

Application Parameters

Spray Gun	HVLP (High Volume Low Pressure) gun
Pressure	2kgf/cm ² (28 psi)

DI materials paste must be homogenized carefully before use, under mechanical mixing at medium speed. During the application, it is necessary to mix the paint from time to time to avoid sedimentation.

Safety Data

Precaution	General precaution in use for the application of paints containing solvents. Flammable product. Therefore never handle near a flame.
Labeling	Part No., Lot No., Manufacture Date, Quantity, Manufacturer
Documentation	Outgoing Inspection Sheet
Storage	Product shelf life is 6 months from the date of manufacture while stored under original seal. Store in a cool, dry location at temperatures between 15~20°C

How to Order

P/N : IDP — AAA

① ②

① Serial Number

② Materials Type

-01S : solvent-based system



01
02
03
04
05_Conductive Paste
06
07
08
09
10
11

SMT Gasket

SMD is an abbreviation of Surface-Mounted Devices and means a surface mount element. SMT GASKET is a conductive gasket using for circuit ground SMT (Surface Mount Technology) to reduce the electrical / electronic malfunction and its EMI noise. Existing EMI shielding gaskets are produced in wrapping the foam with conductive fabric but it does not have high temperature resistance. SMT Gaskets have the excellent electrical conductivity, high heat resistance and SMT mountable characteristics for automatic soldering procedure. DI materials developed SMT gasket to follow such electronics industry trend. SMT gasket is superior grounding gasket to existing one at the electrical and physical characteristics, and an up-graded product of EX-FLEXIL by the integrated process technology of DI materials, the leader of the EMI gasket technology.

This SMT Gasket has developed to go with the trend of environment restriction.

※ This product is patented for unique technology.

Patent No. : 10-0813095, 10-0958890, 10-1047057, 10-1054251, 10-1131749

China(SOP114648CN), PCT/KR2010/003114, Europe(10777921.7), Japan, USA

IDSMT series

Wrapping Type (Sn, Au)



Ultra soft Wrapping Type (Sn, Au)



Coating Type



Coating Type (Side-Contact)



IDCF series

Hard Type (Press)



Soft Type (Casting)



IDSMT-W series

■ Features

- Excellent grounding characteristics from a wide area of grounding
- Excellent electrical conductivity
- The stabilization of components due to mounting levelly
- Excellent reliability (repeated compression, brine-atomizing test pass)
- Precise reel packaging for the accurate work
- Superior thermo-stable characteristics
- High adhesion after SMT
- EMI Shielding
- Impedance matching function of PCB or FPCB
- Excellent Thermal Transfer
- Excellent ESD (Electrostatic discharge)
- Cushion and anti-shock after SMT
- EMI noise attenuation its power loss property

■ Structure

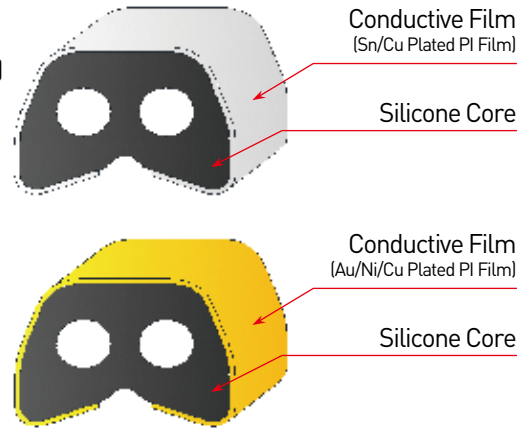

■ Applications

- Electrical contact
- Grounding & Cushion and anti-shock
- TV, Tablet, PC, Camera, Navigation, MP3, Display

■ Specifications

Item		Test Method	Properties
Material Description	Base Material	-	Silicone rubber & PI Film
	Color	Visual	Silver / Gold
Standard Size	Width	Projector	Customized
	Height		
	Length		
Operation Temp (°C)		Internal Test Method	-40 ~ 150 °C
Reflow Soldering Temp (°C).		Internal Test Method	Max. 260 °C
Electric Resistance (Ω)	Origin	HIOKI 3540 mΩ HITESTER	Max. 0.1
	2nd Reflow (After IPA cleaned)		Max. 0.1
	Thermo-hygrostat		Max. 0.1
	Salt Spray		Max. 0.1
	Thermal Shock		Max. 0.1
Soldering Strength (gf/cm)		UTM	Min. (Product LengthX150)gf/mm
Compression-Deflection Rate (%)		40% Compression, 70°C x 22hr	Min. 90
		40% Compression 10,000times	Min. 90
Flammability		UL 94	UL 94-V1
RoHS & Halogen Free		Pb, Cd, Hg, Cr ⁶⁺ , PBBs, PBDEs, Br, Cl	N.D.

■ How to Order

P/N : IDSMT - W - AAA - BBB - CCC - DDD

① ② ③ ④ ⑤ ⑥

- ① Serial Number
- ② W : Wrapping
- ③ Width (mm)
- ④ Height (mm)
- ⑤ Length (mm)
- ⑥ Type : H [Sn plated Film with a hole], HG [Au plated Film with a hole]
N [without a hole], GN [Au plated Film without a hole]

[For Example]

IDSMT-W-4-5-6-H

- ▶ Wrapping
- ▶ Width : 4mm
- ▶ Height : 5mm
- ▶ Length : 6mm
- ▶ Type : H

IDSMT – UW series

Features

- Excellent grounding characteristics from a wide area of grounding
- Excellent electrical conductivity
- The stabilization of components due to mounting levelly
- Excellent reliability
(repeated compression, brine-atomizing test pass)
- Precise reel packaging for the accurate work
- Superior thermo-stable characteristics
- High adhesion after SMT
- EMI Shielding
- Impedance matching function of PCB or FPCB
- Excellent Thermal Transfer
- Excellent ESD (Electrostatic discharge)
- Cushion and anti-shock after SMT
- EMI noise attenuation its power loss property
- Softer type compared to IDSMT-W series

Structure

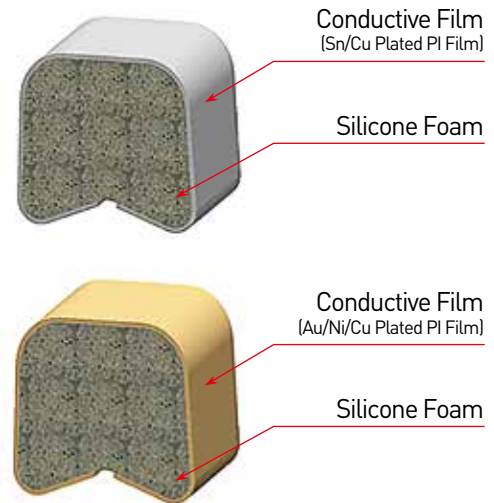

Specifications

Item		Test Method	Properties
Material Description	Base Material	-	Conductive Silicone & Silicone rubber & Sn plated Cu Foil
	Color	Visual	Dark gray / Gray
Standard Size	Width	Projector	Customized
	Height		
	Length		
Operation Temp (°C)		Internal Test method	-40 ~ 150 °C
Reflow Soldering Temp (°C).		Internal Test method	Max. 260 °C
Electric Resistance	Origin	HIOKI 3540 mΩ HITESTER	Max. 0.1
	2nd Reflow(After IPA cleaned)		Max. 0.1
	Thermo-hygrostat		Max. 0.1
	Salt Spray		Max. 0.1
	Thermal Shock		Max. 0.1
Soldering Strength (gf/cm)		UTM	Min. (Product LengthX150)gf/mm
Compression-Deflection Rate (%)		40% Compression, 70°C x 22hr	Min. 90
		40% Compression 10,000times	Min. 90
Flammability		UL 94	UL 94-V0
RoHS & Halogen Free		Pb, Cd, Hg, Cr ⁶⁺ , PBBs, PBDEs, Br, Cl	N.D.

How to Order

P/N : IDSMT - UW - AAA - BBB - CCC - DDD

① ② ③ ④ ⑤ ⑥

- ① Serial Number
- ② UW : Ultra soft Wrapping
- ③ Width (mm)
- ④ Height (mm)
- ⑤ Length (mm)
- ⑥ Type : N [Sn plated Film without a hole], GN [Au plated Film without a hole]

[For Example]

IDSMT-UW-4-3.5-3-N

- ▶ Ultra Soft Wrapping
- ▶ Width : 4mm
- ▶ Height : 3.5mm
- ▶ Length : 3mm
- ▶ Type : N

IDSMT-S series

Features

- Excellent grounding characteristics from a wide area of grounding
- Excellent electrical conductivity
- The stabilization of components due to mounting levelly
- Excellent reliability(repeated compression, brine-atomizing test pass)
- Precise reel packaging for the accurate work
- Superior thermo-stable characteristics
- High adhesion after SMT
- EMI Shielding
- Impedance matching function of PCB or FPCB
- Excellent Thermal Transfer
- Excellent ESD (Electrostatic discharge)
- Cushion and anti-shock after SMT
- EMI noise attenuation its power loss property

Structure

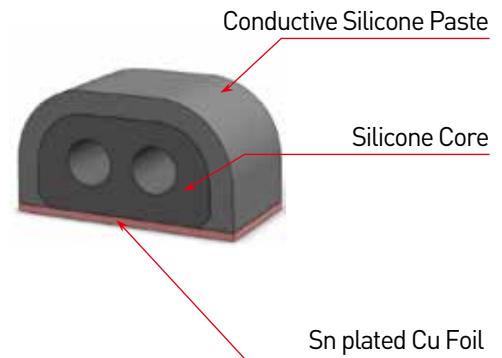

Specifications

Item		Test Method	Properties
Material Description	Base Material	-	Conductive Silicone & Silicone rubber & Sn plated Cu Foil
	Color	Visual	Dark gray / Gray
Standard Size	Width	Projector	Customized
	Height		
	Length		
Heat Resistance (°C)		Internal Test method	-40 ~ 150 °C
Service Temp (°C).		Internal Test method	Max. 260 °C
Electric Resistance	Origin	HIOKI 3540 mΩ HITESTER	Max. 1.0
	2nd Reflow(After IPA cleaned)		Max. 1.0
	Thermo-hygrostat		Max. 1.0
	Salt Spray		Max. 1.0
	Thermal Shock		Max. 1.0
Soldering Strength (gf/cm)		UTM	Min. (Product LengthX150)gf/mm
Compression-Deflection Rate (%)	40% Compression, 70°C x 22hr		Min. 90
	40% Compression 10,000times		Min. 90
Flammability		UL 94	UL 94-V1
RoHS & Halogen Free		Pb, Cd, Hg, Cr ⁶⁺ , PBBs, PBDEs, Br, Cl	N.D.

How to Order

P/N : IDSMT - S - AAA - BBB - CCC - DDD

- ① Serial Number
- ② S : Standard
- ③ Width (mm)
- ④ Height (mm)
- ⑤ Length (mm)
- ⑥ Type : H[Gray color/hole], BH[Black color/hole], N [without a hole]

[For Example]

IDSMT-S-4-5-6-H

- ▶ Standard
- ▶ Width : 4mm
- ▶ Height : 5mm
- ▶ Length : 6mm
- ▶ Type : H

IDSMT-S series (Side contact type)

Features

- Side-Bottom contact type
- Excellent grounding characteristics from a wide area of grounding
- Excellent electrical conductivity
- The stabilization of components due to mounting levelly
- Excellent reliability (repeated compression, brine-atomizing test pass)
- Precise reel packaging for the accurate work
- Superior thermo-stable characteristics
- High adhesion after SMT
- EMI Shielding
- Impedance matching function of PCB or FPCB
- Excellent Thermal Transfer
- Excellent ESD (Electrostatic discharge)
- Cushion and anti-shock after SMT
- EMI noise attenuation its power loss property

Structure

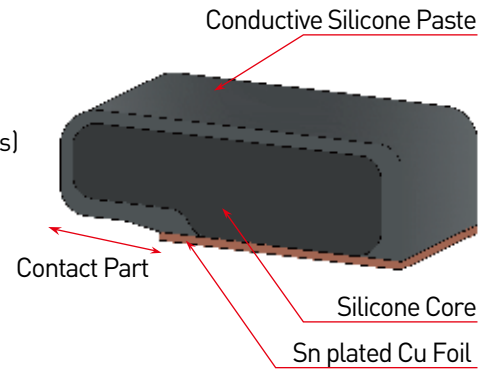

Specifications

Item		Test Method	Properties
Material Description	Base Material	-	Conductive Silicone & Silicone rubber & Sn plated Cu Foil
	Color	Visual	Dark gray / Gray
Standard Size	Width	Projector	Customized
	Height		
	Length		
Operation Temp (°C)		Internal Test method	-40 ~ 150 °C
Reflow Soldering Temp (°C).		Internal Test method	Max. 260 °C
Electric Resistance (°C).	Origin	HIOKI 3540 mΩ HITESTER	Max. 1.0
	2nd Reflow(After IPA cleaned)		Max. 1.0
	Thermo-hygrostat		Max. 1.0
	Salt Spray		Max. 1.0
	Thermal Shock		Max. 1.0
Soldering Strength (gf/cm)		UTM	Min. (Product LengthX150)gf/mm
Compression-Deflection Rate (%)	40% compression of product contact part width, 70°C x 22hr		Min. 90
	40% compression of product contact part width, 10,000times		Min. 90
Flammability		UL 94	UL 94-V1
RoHS & Halogen Free		Pb, Cd, Hg, Cr ⁶⁺ , PBBs, PBDEs, Br, Cl	N.D.

How to Order

P/N : IDSMT - S - AAA - BBB - CCC - DDD
 ① ② ③ ④ ⑤ ⑥

- ① Serial Number
- ② S : Standard
- ③ Width (mm)
- ④ Height (mm)
- ⑤ Length (mm)
- ⑥ Type : H[Gray color/hole], BH[Black color/hole], N [without a hole]
BN[Black color/without a hole]

[For Example]

IDSMT-S-2.9-1-1.9-BN

- ▶ Standard
- ▶ Width : 2.9mm
- ▶ Height : 1mm
- ▶ Length : 1.9mm
- ▶ Type : BN

IDCF series

Features

IDCF is recently developed by DSIC from SMD Finger Strip for the use PCB featuring excellent resilience and electrical properties.

Structure



Specifications

Item	Test Method	Properties
Material Description	Base Material	-
	Color	Conductive Silicone & Au plated Cu Foil
Standard Size	Width	Dark gray / Gray
	Height	Projector
	Length	
Operation Temp (°C)	Internal Test method	-40 ~ 150 °C
Reflow Soldering Temp (°C).	Internal Test method	Max. 260 °C
Electric Resistance (Ω)	Origin	Max. 1.0
	2nd Reflow(After IPA cleaned)	Max. 1.0
	Thermo-hygrostat	Max. 1.0
	Salt Spray	Max. 1.0
	Thermal Shock	Max. 1.0
Soldering Strength (gf/cm)	UTM	Min. (Product LengthX150)gf/mm
Compression-Deflection Rate (%)	40% Compression, 70°C x 22hr	Min. 90
	40% Compression 10,000times	Min. 90
Flammability	UL 94	UL 94-V0
RoHS & Halogen Free	Pb, Cd, Hg, Cr ⁶⁺ , PBBs, PBDEs, Br, Cl	N.D.

How to Order

P/N : IDCF - AAA - BBB T- CCC - DDD - EEE - FFF

① ② ③ ④ ⑤ ⑥ ⑦

- ① Serial Number
- ② None : Hard Type , C : Soft Type
- ③ Height(mm)
- ④ Conductive Silicone Type : SC
Non-Conductive Silicone Type : GS
- ⑤ Width (mm)
- ⑥ Length (mm)
- ⑦ G : Au Plated Cu Foil
BG : Black Color / Au Plated Cu Foil
None: Sn Plated Cu Foil

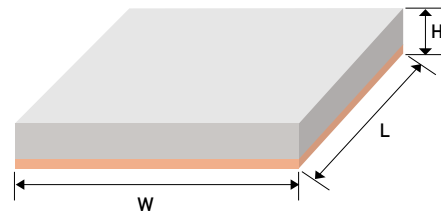

[For Example]

IDCF-0.7T-SC-2.5-1-G

- ▶ Hard Type
- ▶ Width : 2.5mm
- ▶ Height : 0.7mm
- ▶ Length : 1mm
- ▶ Type : G

IDCF-C-0.4T-SC-2-1-G

- ▶ Soft Type
- ▶ Width : 2mm
- ▶ Height : 0.4mm
- ▶ Length : 1mm
- ▶ Type : G

Shielding Gasket

Fabric Gasket

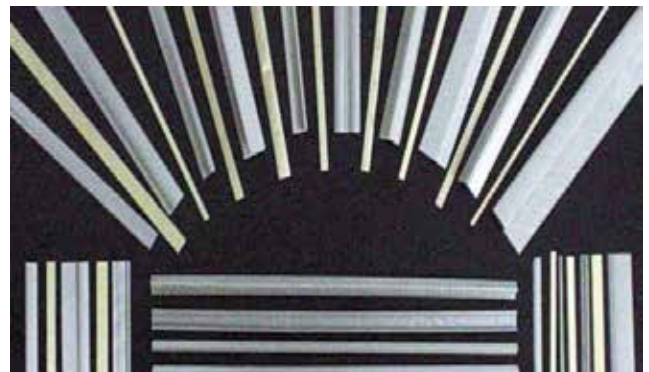
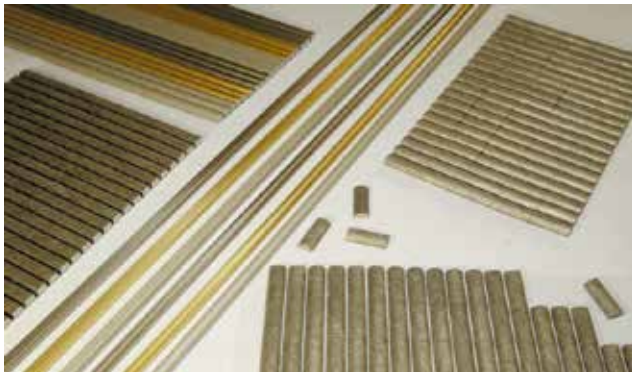

Cushion Gasket

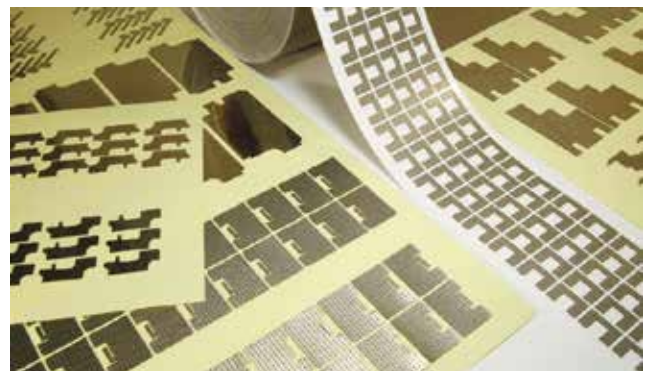
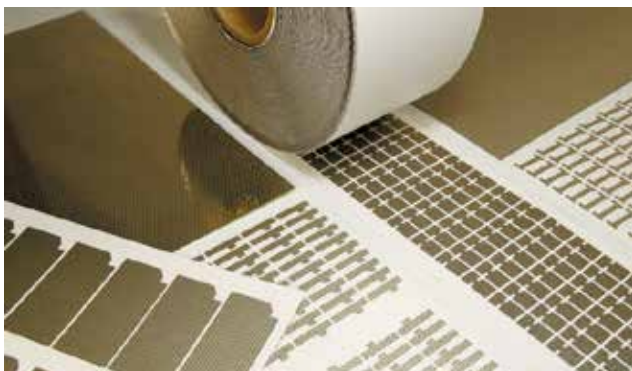

● Introduction

Nowadays, with the rapid development of mobile communication technologies, we are facing a lot of serious problems related to electromagnetic waves from IT products. To cope with these problems, it is necessary to use the EMI Shielding products.

DI materials manufactures a wide range of EMI Shielding and Conductive Products, related to the computer, telecommunications, military equipment, general electronics, medical equipments and automotive industries. These include **Fabric Gasket**, and **Cushion Gasket**.

DI materials EMI Shielding Products have been awarded ISO 9001 and 14001 certification and have patents unique designed to perform good shielding effects, and they have meet UL requirements.

This catalogue is designed to provide technical specifications and material characteristics for all categories of shielding gaskets and conductive products available from DI materials . These products' list is as follows.

● Fabric Gasket

DI materials's ID Series, Fabric Gaskets consist of an electrically conductive fabrics on a highly compressed elastomer foam core. These have been designed to meet commercial EMI Shielding applications where wide tolerance exists.

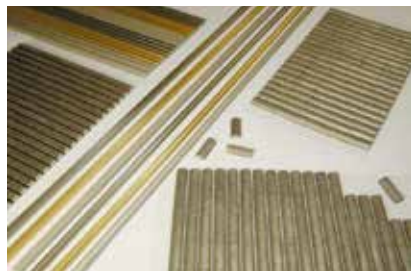

● Cushion Gasket

DI materials has developed EMI Cushion Gasket which is composed of a conductive foam. The innumerable cells of foam are plated with Cu-Ni and it is very flexible and provides good SE(shielding effectiveness).

It is very easy to mount on the substrates due to conductive tape attached to the rear side of Cushion Gasket. Therefore, it can be widely applied because various shapes are available.

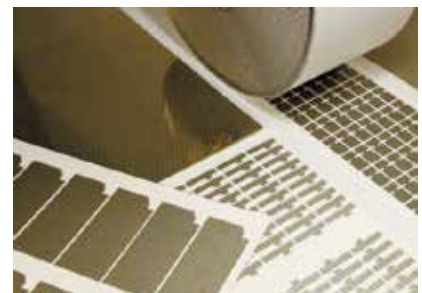
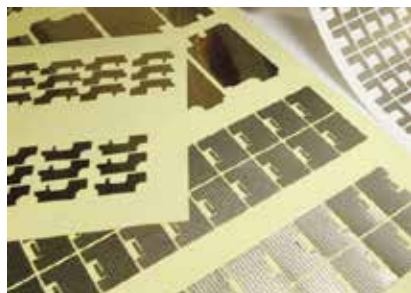

● **Conductive Fabrics**

P/N	SE (dB) [30MHz~1.5GHz]	Thickness (mm)	Surface Resistivity (Ω/°C)	SE (dB) [30MHz~1.5GHz]
IDF-NRA	Ripstop / Ni + Cu + Ni	0.10	≤ 0.08	More than Avg. 60
IDF-NK	Woven / Ni + Cu + Ni	0.10	≤ 0.08	More than Avg. 60

■ **Quality Performance**

● **SE***

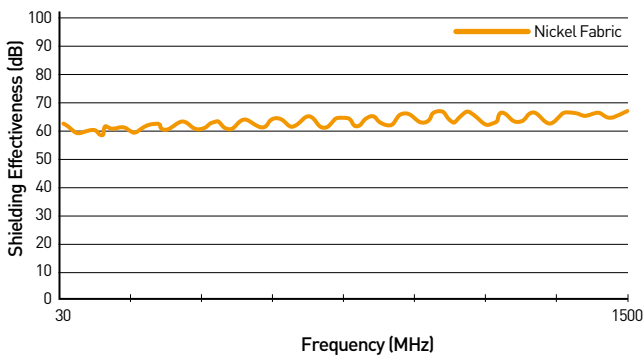

● **Flammability**

Product Name	UL94 Flame Class	UL File No.
Fabric Gasket	V-0, HF-1, HBF	E311094

■ **How to Packing**

DI materials's unique packing methods provide customers with very good producibility and inventory stock control. This method is applicable to small and big sizes in mass production, and we also provide 1000mm per a piece as standard length for customer inventory.

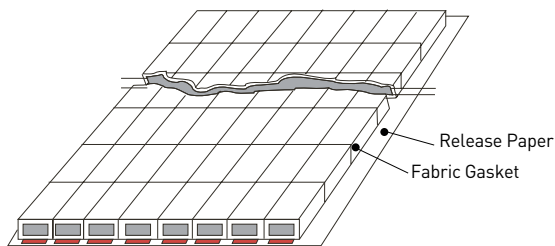

[Small Sizes]

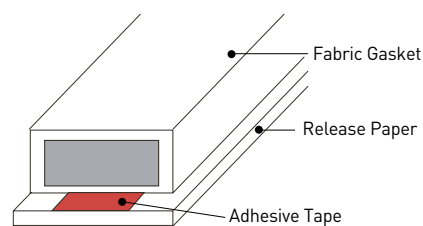

[Big Sizes]

How to Order

Standard Products

P/N : ID - 45Q NK Z - XX - RS YY - ZZ - 23 - C 08 - S

① ② ③ ④ ⑤ ⑥ ⑦ ⑧ ⑨ ⑩ ⑪ ⑫

① Serial Description

② Type of Sponge

Sponge Part No	Description	Sponge Part No	Description
32B	32kg/m ³ PU Foam Black	45B	45kg/m ³ PU Foam Black
32Q	32kg/m ³ PU Foam Brown (Halogen-Free)	45Q	45kg/m ³ PU Foam Brown (Halogen-Free)
		45W	45kg/m ³ PU Foam White

③ Type of Fabric

Fabric Part No	Description	Fabric Part No	Description
NK	Nickel Fabric (Plain Woven)	NRA	Nickel Fabric (Ripstop)

④ Type of Hotmelt

Hotmelt Part No	Description	Hotmelt Part No	Description
H	Hotmelt (Normal)	Z	Flame Retardant Hotmelt (Halogen-Free)
F	Flame Retardant Hotmelt		

⑤ Width of Fabric Gasket (mm)

⑥ Type of Fabric Gasket Shape

None : Rectangular Type (Standard), RN, RS, LS, LN, N, F Type

⑦ Height of Fabric Gasket (mm)

⑧ Length of Fabric Gasket (mm)

⑨ Type of Pressure Sensitive Adhesive (PSA)

PSA Part No	Description	PSA Part No	Description	PSA Part No	Description
00	110QJ	AF	ID-A33	2300	ID-23N11+110QJ
23	ID-23N11	N	Without PSA		

⑩ Position of PSA

Part No	Description	Part No	Description
C	Center(Standard)	UL	Double Side
B	Dual Side	D	Refer to Drawing
S	Side		

⑪ Width Dimension of PSA (※None : Standard)

⑫ S : Press, None : Non Press

01
02
03
04
05
06
07_Shielding Gasket
08
09
10
11

● Building a Part Number

P/N : ID - 45B NK H - 10 - 5 - 1000 - 00 - C
 ① ② ③ ④ ⑤ ⑥ ⑦ ⑧ ⑨

- ① Serial No
- ② 45kg/m³ PU Foam Black
- ③ Nickel Fabric (Plain Woven)
- ④ Hotmelt (Normal)
- ⑤ Width : 10mm
- ⑥ Height : 5mm
- ⑦ Length : 1,000mm
- ⑧ Non-Conductive Tape
- ⑨ Position of PSA : Center

P/N : ID - 45Q NK Z - 10 - RN 5 - 500 - 23 - C 9
 ① ② ③ ④ ⑤ ⑥ ⑦ ⑧ ⑨ ⑩⑪

- ① Serial No
- ② 45kg/m³ PU Foam Brown (Halogen-Free)
- ③ Nickel Fabric (Plain Woven)
- ④ Flame Retardant Hotmelt (Halogen-Free)
- ⑤ Width : 10mm
- ⑥ Shape
- ⑦ Thickness : 5mm
- ⑧ Length : 500mm
- ⑨ Conductive Tape
- ⑩ Position of PSA : Center
- ⑪ Width Dimension of PSA : 9mm

● Type of Fabric Gasket Shape

① Rectangular

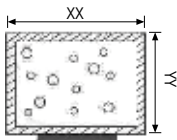

② "RN"

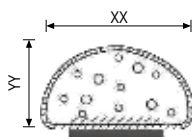

③ "RS" (with support)

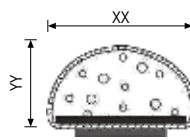

④ "LS"

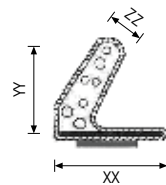

⑤ "LN"

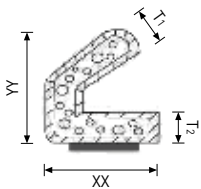

⑥ "N" (nothing inside)

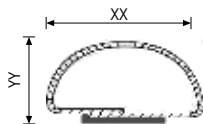

⑦ "F"

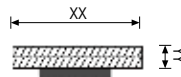

⑧ "D-Sub"

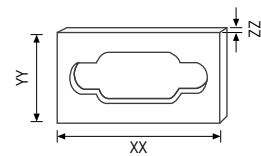

Cushion Gasket - NOF series

Applications

- Display Part of Mobile Phones
- Speaker Ear & Hole for Mobile Phones

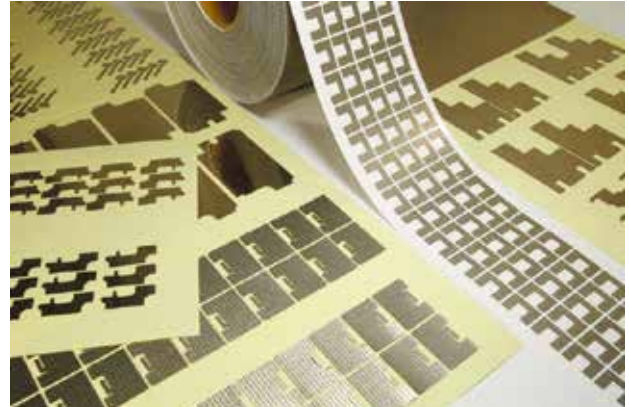
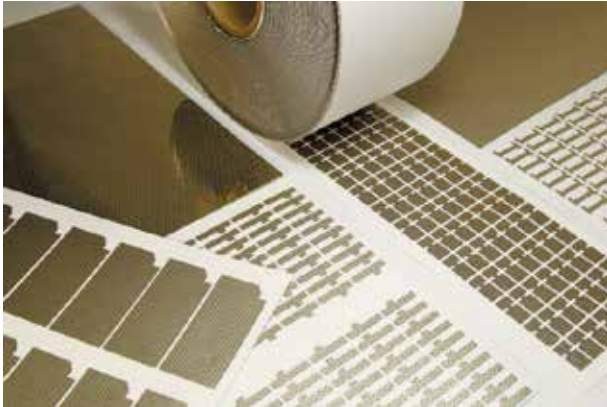

NOF Series

Material & Structure

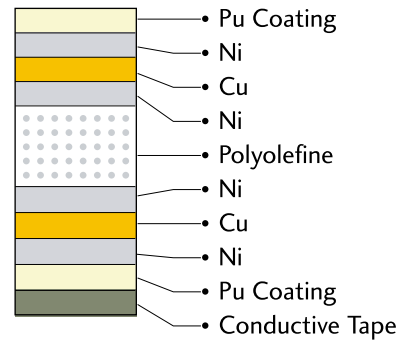
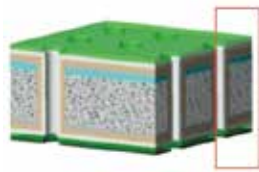

Characteristics

Part No (Unit)	Thickness (mm)	Contact Resistivity (Ω/in^2)	Adhesive Strength (gf/25mm)	Shielding Effectiveness (dB)	Remark
NOF01 (01=23N11 Tape)	0.6, 1.1T	Max0.1	Min1,000	Min. 60	MOQ 500 SQM

How to order

Order by Shape or Sheet Type

P/N : ID - NOF01 - 0.4T - AAA - BBB - S

① ② ③ ④ ⑤ ⑥

- ① Serial Number
- ② Part Number
- ③ Thickness (mm)
- ④ Width (mm)
- ⑤ Length (mm)
- ⑥ Type : S (Shape)
D (Refer to drawing)
None (Rectangular)

[For Example]

ID-NOF01-0.4T-210-300

- ▶ Thickness : 0.40mm
- ▶ Width : 210mm
- ▶ Length : 300mm
- ▶ None : Rectangular type

Order by Roll Type

P/N : ID - NOF01 - 0.6T - AAA - 50M

① ② ③ ④ ⑤

- ① Serial Number
- ② Part Number
- ③ Thickness (mm)
- ④ Width (mm)
- ⑤ Length (m)

[For Example]

ID-NOF01-0.6T-210-50M

- ▶ Thickness : 0.60mm
- ▶ Width : 210mm
- ▶ Length : 50M

Conductive Fabric & Tape

Conductive Fabric

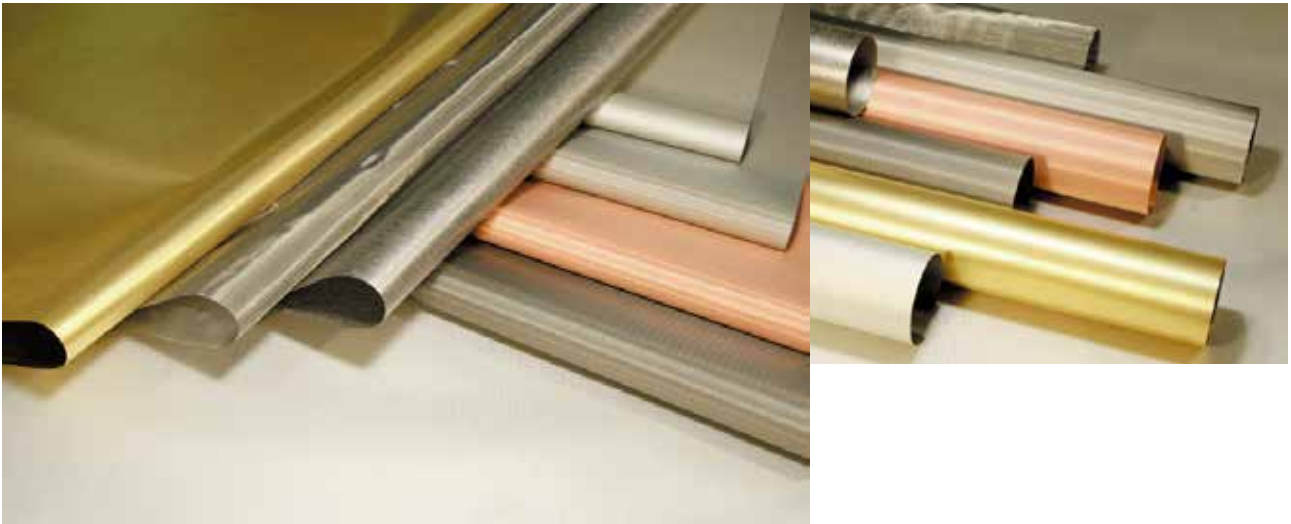

Conductive Tape

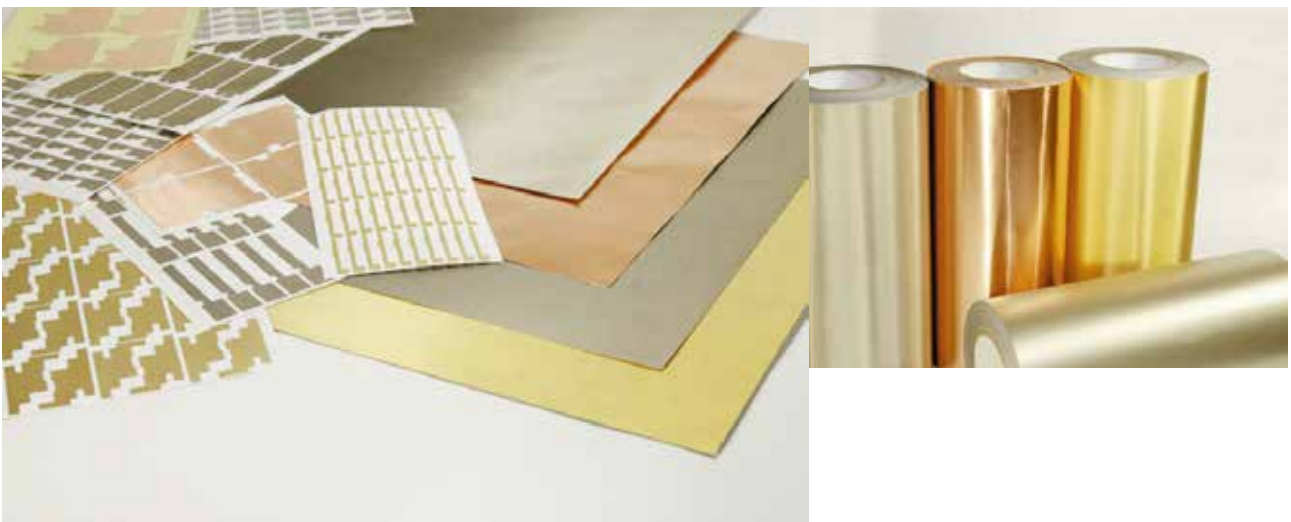

● Introduction

Nowadays, with the rapid development of mobile communication technologies, we are facing a lot of serious problems related to electromagnetic waves from IT products. To cope with these problems, it is necessary to use the EMI Shielding products. DI materials manufactures a wide range of EMI Shielding and Conductive Products, related to the computer, telecommunications, military equipment, general electronics, medical equipments and automotive industries. These include **Fabric Gasket**, and **Cushion Gasket**.

DI materials EMI Shielding Products have been awarded ISO 9001 and 14001 certification and have patents unique designed to perform good shielding effects, and they have meet UL requirements.

This catalogue is designed to provide technical specifications and material characteristics for all categories of shielding gaskets and conductive products available from DI materials . These products' list is as follows.

● Conductive Fabric

Conductive Fabric is manufactured with Ni and Cu plated on polyester fabrics. The base layer is the highly conductive Cu, with or without an outer layer of Ni for corrosion resistance.

Ni/Cu/Ni coated polyester fabrics offer excellent electric conductivity, SE and anticorrosion for a diverse range of requirements.

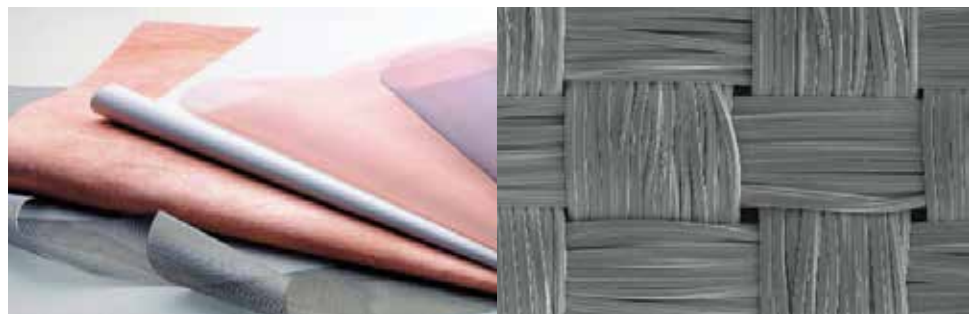

● Conductive Tape

Conductive Tapes are composed of a conductive substrate and adhesive. These products have been designed to meet commercial EMI shielding and grounding properties. Furthermore, these can offer inflammability and durability in a thin, lightweight and flexible shielding design.



Conductive Fabric

Applications

- Shield Screen
- Shield Gasket
- Shield Tape
- Cable Shield
- Radar Reflection
- Shield Window and etc.
- ESD Sheet
- Clothes
- Tempest Room

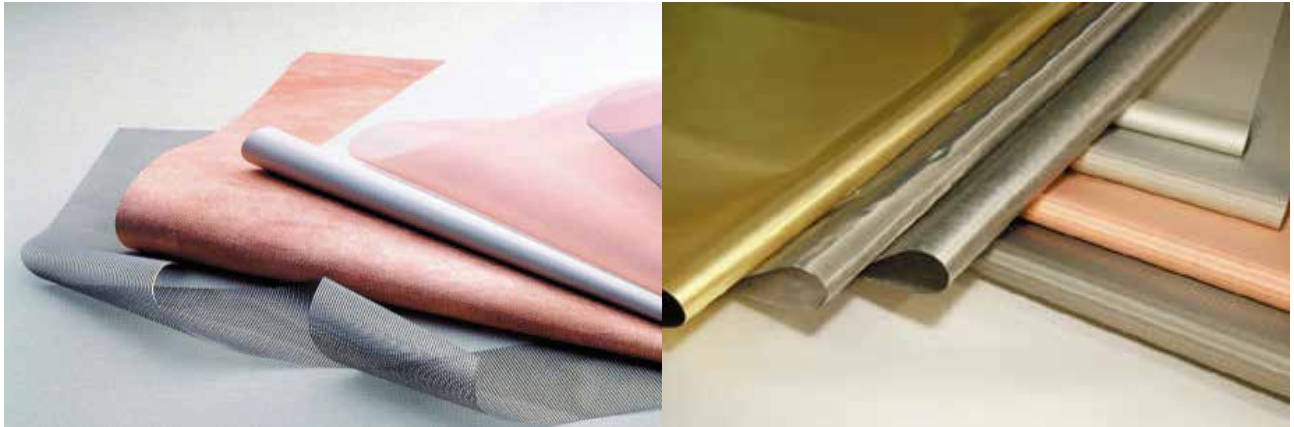

Structure (Woven Fabric)

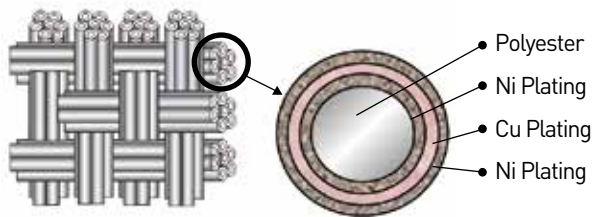

[Woven]

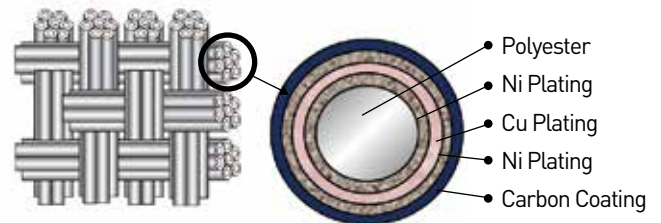

[Woven : Carbon Coating]

Conductive Fabrics (Base Material : Polyester)

P/N	Structure of PET Plating Metal	Width (mm)	Thickness (mm)	Surface Resistivity (Ω/in^2)	Shielding Effectiveness (dB)	Remarks
IDF-NRA	Ni+Cu+Ni	1000	0.100	≤ 0.08	≥ 60	Ripstop
IDF-20N	Ni+Cu+Ni	1000	0.080	≤ 0.10	≥ 60	Mesh
IDF-CK	Ni+Cu+Ni+Carbon	1000	0.100	≤ 0.08	≥ 60	Carbon Coating

Conductive Tape

Applications

- Wire Harness
- Special Type Gasket
- Washer
- Grounding
- Various Shielding and etc.

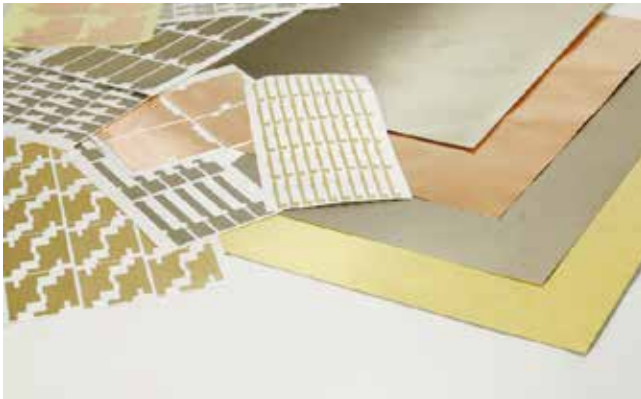

How to Order

Order by Shape or Sheet Type

P/N : ID - NK01 - 0.13 T - AAA - BBB - S

① ② ③ ④ ⑤ ⑥

- ① Serial Number
- ② Part Number
- ③ Thickness (mm)
- ④ Width (mm)
- ⑤ Length (mm)
- ⑥ Type : S (Shape)

D (Refer to drawing)

None (Rectangular)

[For Example]

ID-NK01-0.13T-20-30

- ▶ Thickness : 0.13mm
- ▶ Width : 20mm
- ▶ Length : 30mm
- ▶ None : Rectangular type

Order by Roll Type

P/N : ID - NK01 - 0.13 T - AAA - 50M

① ② ③ ④ ⑤

- ① Serial Number
- ② Part Number
- ③ Thickness (mm)
- ④ Width (mm)
- ⑤ Length (m)

[For Example]

ID-NK01-0.13T-210-50M

- ▶ Thickness : 0.13mm
- ▶ Width : 210mm
- ▶ Length : 50M





Specifications

● Metal Foil Tape Series

P/N	Structure & Dimension	T (mm)	W (mm)	L (M)	Contact Resistivity (Ω)	Adhesive Strength (gf/25mm)	Remarks
ID-A01 (100)	 Al Foil Conductive Adhesive Release Paper	0.070	1000	50	≤ 0.1	≥ 1,000	Halogen-Free
ID-A11 (104)	 Conductive Adhesive Al Foil Conductive Adhesive Release Paper	0.090	1000	50	≤ 0.1	≥ 1,000	Halogen-Free
ID-AT11 (T104)	 Conductive Adhesive Al Foil Conductive Adhesive Release Paper	0.050	1000	50	≤ 0.1	≥ 1,000	Halogen-Free
ID-A02 (1000)	 Al Foil Non-Conductive Adhesive Release Paper	0.10	500	50	-	≥ 1,000	Halogen-Free
ID-A33 (1046)	 Conductive Adhesive Al Foil Conductive Adhesive Release Paper	0.09	500	50	≤ 0.2	≥ 1,000	Flame Retardant
ID-AZ33	 Conductive Adhesive Al Foil Conductive Adhesive Release Paper	0.08	500	50	≤ 0.2	≥ 1,000	Flame Retardant (Halogen-Free)
ID-C01 (101)	 Cu Foil Conductive Adhesive Release Paper	0.07	630	25	≤ 0.1	≥ 1,000	Halogen-Free









Specifications

● Conductive Fabric Tape (Double Side Series)

P/N	Structure & Dimension	T (mm)	W (mm)	L (M)	Contact Resistivity (Ω)	Adhesive Strength (gf/25mm)	Remarks
ID-23N11 (1045)	 Conductive Adhesive Conductive Fabric Conductive Adhesive Release Paper	0.11	1000	50	≤ 0.05	≥ 1,000	Halogen-Free
ID-20N11 (1042)	 Conductive Adhesive Conductive Mesh Conductive Adhesive Release Paper	0.11	1000	50	≤ 0.10	≥ 1,000	Halogen-Free
ID-23N33	 Conductive Adhesive Conductive Fabric Conductive Adhesive Release Paper	0.11	1000	50	≤ 0.2	≥ 1,000	Flame Retardant
ID-23NZ33	 Conductive Adhesive Conductive Fabric Conductive Adhesive Release Paper	0.11	1000	50	≤ 0.05	≥ 1,000	Flame Retardant (Halogen-Free)

Specifications

● Conductive Fabric Tape (Single Side Series)

P/N	Structure & Dimension	T (mm)	W (mm)	L (M)	Contact Resistivity (Ω)	Adhesive Strength (gf/25mm)	Remarks
ID-NRA01 (102)	 Conductive Fabric (IDF-NRA) Conductive Adhesive Release Paper	0.12	1000	50	≤ 0.1	≥ 1,000	Halogen-Free
ID-NRA02 (1020)	 Conductive Fabric (IDF-NRA) Non-Conductive Adhesive Release Paper	0.12	1000	50	-	≥ 1,500	Halogen-Free
ID-NRA03 (1026)	 Conductive Fabric (IDF-NRA) Conductive Adhesive Release Paper	0.14	1000	50	≤ 0.2	≥ 1,000	Flame Retardant
ID-NK01 (K102)	 Conductive Fabric (IDF-NK) Conductive Adhesive Release Paper	0.13	1000	50	≤ 0.1	≥ 1,000	Halogen-Free
ID-NK02 (K1020)	 Conductive Fabric (IDF-NK) Non-Conductive Adhesive Release Paper	0.13	1000	50	-	≥ 1,000	Halogen-Free
ID-NK03 (K1026)	 Conductive Fabric (IDF-NK) Conductive Adhesive Release Paper	0.14	1000	50	≤ 0.2	≥ 1,000	Flame Retardant
ID-NKZ03	 Conductive Fabric (IDF-NK) Conductive Adhesive Release Paper	0.13	1000	50	≤ 0.1	≥ 1,000	Flame Retardant (Halogen-Free)
ID-NK(T)Z03	 Top Coating Conductive Fabric (IDF-NK) Conductive Adhesive Release Paper	0.13	1000	50	≤ 0.1	≥ 1,000	Flame Retardant (Halogen-Free)

01
02
03
04
05
06
07
08 _ Conductive Fabric & Tape
09
10
11

Metal Clip

Finger Strip

DI materials's Finger Strip is made of stainless steel or phosphor bronze, beryllium copper. It depends on the customers' demand about the plating metal such as Nickel, Tin or Gold. Finger Strip provides excellent EMI Shielding due to its high electric conductivity and strong elastic property as a gasket.



SMD Finger

SMD Finger is recently developed for the use of PCB grounding. It shows excellent resilience and electrical properties. Plated Gold has tremendous conductivity, so it is eventually suitable for grounding of various PCBs.

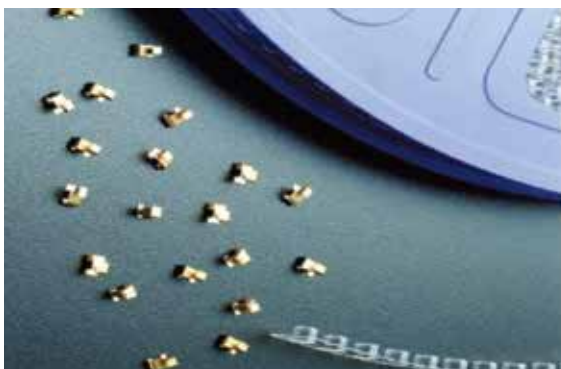

Finger Strip

Applications

- Front Panel Handles
- Chassis Covers
- Plug-in Units
- Back Planes

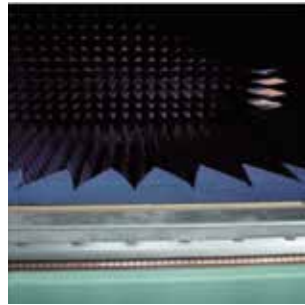
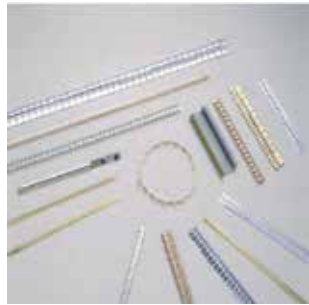
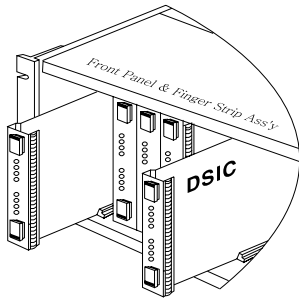

Specifications

● BeCu Alloy (C17200) & PSA Tape

Chemical Composition		Mechanical & Electrical Properties		PSA
Be	1.8~2.0%	Tensile Strength	1220~1480 kgf/cm ² [171~206 ksi]	Acrylic Adhesive
Co + Ni	≥ 0.2%			
Co + Ni + Fe	≤ 0.6%	Yield Strength	2860~3570 kgf/cm ² [400~508 ksi]	
Pb	≤ 0.02%	Hardness Rockwell C 36	Rockwell C 36~43	
Cu	Balanced	Temp. Range	-30~105°C	

● Plating Finish with Type of Surface

Finish Plating	Recommended Mating and Mounting Surface
Cu	Brass, Cu, Ni-Cu Alloy, Monel, Stainless Steel, Ag
Ni	Brass, Carbon Steel, Cu, Fe, Ni, Stainless steel, Sn
Sn	Al, Al alloy, Be, Carbon Steel, Ni, Sn, Zn

Galvanic Potential Difference between Plating Metals

(Unit : V)

Content	ANODE											
	Mg	Zn	Al	Cd	Sn	Iron, Steel	Cr	Brass	Cu, Bronze	Ni, Monel	SUS	
C A T H O D E	Zn	0.75										
	Al	1.05	0.029									
	Cd	1.05	0.029	0.01								
	Sn	1.36	0.060	0.31	0.31							
	Iron,Steel	1.30	0.029	0.32	0.32	0.01						
	Cr	1.39	0.65	0.34	0.34	0.03	0.02					
	Brass	1.54	0.78	0.50	0.50	0.22	0.20	0.02				
	Cu,Bronze	1.58	0.82	0.55	0.55	0.24	0.23	0.11	0.02			
	Ni,Monel	1.58	0.82	0.56	0.56	0.25	0.25	0.12	0.03	0.01		
	SUS	1.67	0.91	0.64	0.64	0.35	0.32	0.20	0.11	0.02	0.08	
	Ag	1.78	1.02	0.75	0.75	0.44	0.43	0.31	0.22	0.21	0.19	0.11

▶ Recommended in the presence of salts and other electrolytes.
▶ Preferred, in high humidity environment.

Design concept

DI materials's Finger Strip's Shielding design incorporate two types, namely 3 Points and 2 Points Contact.

Content	3 Points Contact	2 Points Contact
Structure		
Application	For area where both surfaces can be connected by contact at least one point of the shielding gasket profile on each surface	For area where both surfaces can be connected by contact at least one point of the shielding gasket profile on one side and the conductive adhesive on the other
Temp. Range [°C]		-30~105°C

How to Fix Finger Strip on Hardware

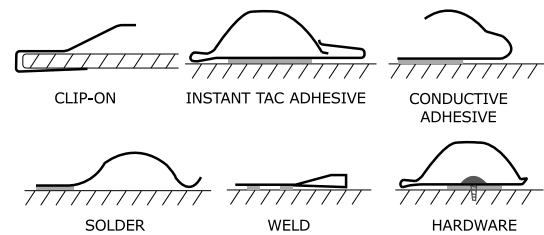

Correct Applications

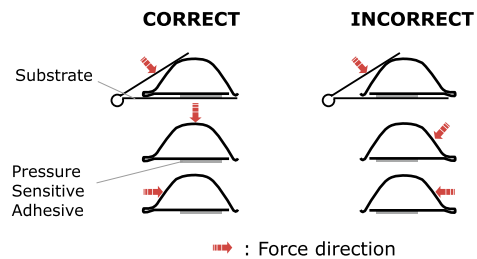

Quality Performance

Compression-Deflection

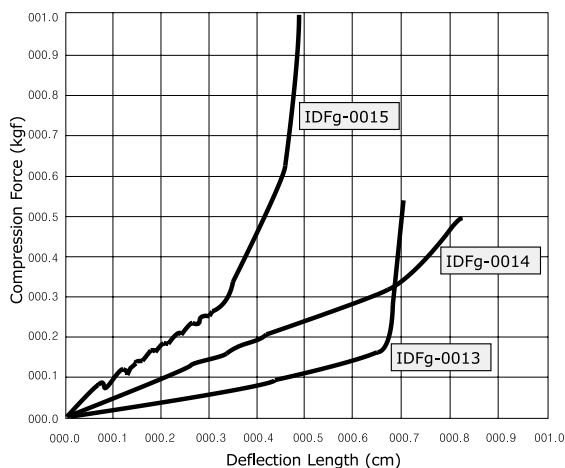

How to Order

P/N : IDFG - AAA - BBB - CCC - DDD - EEE

- ①
- ②
- ③
- ④
- ⑤

- ① Serial Number
- ② Length (mm) / Pin
- ③ Plating (00 : None, 11 : Tin, 22 : Gold, 33 : Nickel)
- ④ Tape
(00 : Double Side Non-Conductive Adhesive, 11 : ID-A11, 22 : ID-A11 + Double Side Non-Conductive Adhesive, 33 : None)
- ⑤ Width of Tape (mm)

Structure & Dimensions

PART NO.	Cross Section and Dimensions (mm)	Standard Fixing Method	Standard Plating Standard Length Standard Material
IDFg-001 (A : 8.0mm) IDFg-002 (A : 11.7mm)		• CLIP	<ul style="list-style-type: none"> • None • 405mm/27Pins • SUS 301
IDFg-006		• CLIP	<ul style="list-style-type: none"> • Gold/None • 200mm/27Pins • BeCu
IDFg-007		• Adhesive Tape	<ul style="list-style-type: none"> • Gold/None • 405mm/162Pins • BeCu
IDFg-0010A	<p>Very Simple and Economic</p>	• CLIP	<ul style="list-style-type: none"> • Nickel • 600mm/80Pins • Phosphor Bronze

Structure & Dimensions

PART NO.	Cross Section and Dimensions (mm)	Standard Fixing Method	Standard Plating Standard Length Standard Material
IDFg-0014		<ul style="list-style-type: none"> • Clip 	<ul style="list-style-type: none"> • Tin • 394mm/31Pins • BeCu
IDFg-0015		<ul style="list-style-type: none"> • Clip 	<ul style="list-style-type: none"> • Tin • 400mm/42Pins • BeCu
IDFg-0016		<ul style="list-style-type: none"> • Clip 	<ul style="list-style-type: none"> • Tin • 406mm/22Pins • BeCu

01
02
03
04
05
06
07
08

09 _ Metal Clip

10
11

PART NO.	Cross Section and Dimensions (mm)	Standard Fixing Method	Standard Plating Standard Length Standard Material
IDFg-0018		<ul style="list-style-type: none"> • Clip 	<ul style="list-style-type: none"> • Tin • 408mm/12Pins • BeCu
IDFg-0020		<ul style="list-style-type: none"> • Adhesive Tape Slot Mount 	<ul style="list-style-type: none"> • Nickel • 190mm/45Pins • BeCu
IDFg-0024		<ul style="list-style-type: none"> • Adhesive Tape 	<ul style="list-style-type: none"> • None • 375mm • BeCu

SMD Finger

Applications

- Fixing the Shield Can
- Grounding
- Battery Contacts



Shape and Description

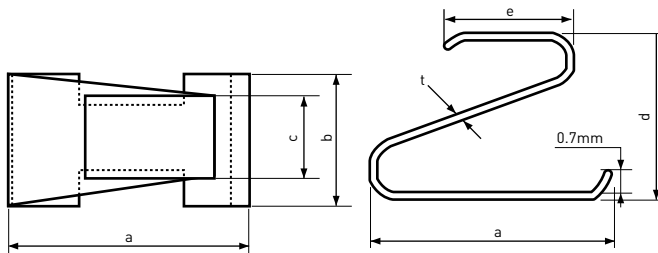

Unit : mm

P/N	a	b	c	d	e	f	g	h	Carrier Width	Carrier Length	Packing In Reel	plating	Base Material
IDFg-0023-01	5.24	3.0	1.8	3.7	2.9	0.1	-	-	3.20	5.20	2,250	Au	BeCu/SUS
IDFg-0023-02	3.94	2.0	1.6	3.1	2.4	0.1	-	-	2.20	4.00	2,750	Au	BeCu/SUS
IDFg-0023-03	3.74	2.0	1.2	1.5	2.4	0.1	-	-	2.20	3.70	1,250	Au	BeCu
IDFg-0023-05	5.78	3.0	1.8	5.55	2.9	0.1	-	-	3.20	5.70	1,500	Au	SUS
IDFg-0023-06-1	3.8	2.5	2.1	2.7	1.8	0.1	-	-	2.90	4.00	3,000	Au	BeCu
IDFg-0023-07	5.2	3.4	2.8	4.0	2.0	0.1	-	-	3.70	5.50	1,800	Au	BeCu
IDFg-0023-10	5.0	5.0	8.0	2.4	5.0	0.05	-	-	-	-	1,000	Au	BeCu
IDFg-0023-12	5.1	3.4	2.8	5	2.4	0.1	-	-	3.70	5.50	1,600	Au	BeCu
IDFg-0023-13	5.1	3.4	3.2	6.5	2.45	0.1	-	-	3.70	5.50	1,000	Au	BeCu
IDFg-0023-14	3.55	2.7	2.4	3.0	1.8	0.1	-	-	3.20	5.40	2,500	Au	BeCu
IDFg-0023-16	4.7	5.66	2.0	2.7	0.15	1.35	1.6	2.0	-	-	2,000	Au	BeCu
IDFg-0023-18	5.0	1.6	2.6	0.85	1.65	1.2	2.0	1.5	-	-	3,000	Au	SUS
IDFg-0023-21	2.5	7.0	3.65	4.25	0.15	-	-	-	-	-	2,000	Au	BeCu

Characteristics (Be-Cu)

Contents	Properties
Tensile Strength (kgf/cm ²)	530~632 (7.53~8.98 ksi)
Yield Strength (kgf/cm ²)	430~580 (6.11~8.24 ksi)
Elongation (%)	20~45



Shield Window



Window (For Various Displays)

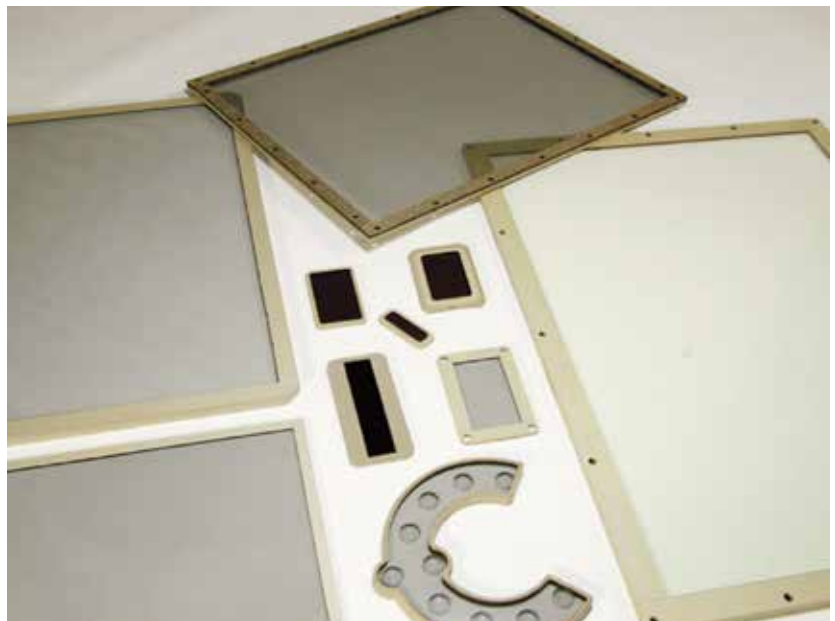

Window

Features

Window is specially designed to feature Optical Transmission and EMI SE. It consists of two layers of optical substrates with a layer of conductive wire mesh between them. Therefore, it shows remarkable EMI SE and Transparency in any environment. DI materials's Window can be economically matched to most display units to minimize image distortion and maximize SE.

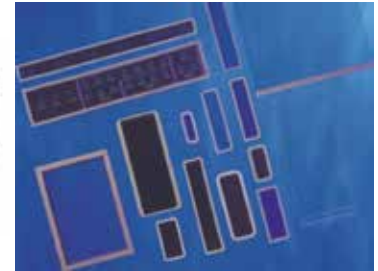

Applications

- Control Panels
- Printers
- Peripheral Equipments
- Large Electrode Displays

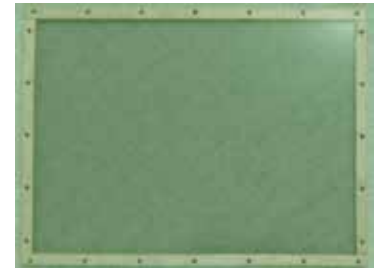
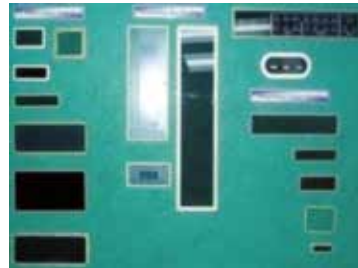

Specifications

Transparent Substrate

Properties	Materials	
	Acrylic	Remark
Transmission	92%	
Bending Strength	120 kgf/cm ² [1.71 ksi]	
Temp. Rating	85°C	Condition in RH. 65%

Color	Available	Gloss Value (%)
Clear	0	55
Smoke Gray	0	55
Red	0	55
Green	0	55

Conductive Mesh

Mesh Count	Materials	
	Blackened Cu + Ni Plated	
Woven #80	0	
Woven #135	0	

Grounding Bus

Grounding	Surface Resistivity	Usage
Silver Plating	≤ 0.5Ω/□	Small size window
Copper Plating	≤ 1.0Ω/□	Big size window

Structure

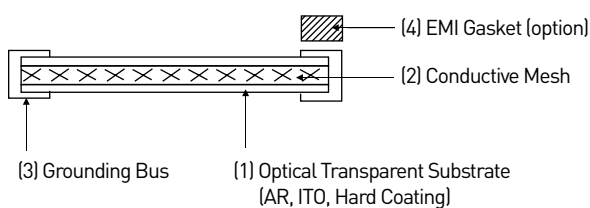

How to Fix Window on Hardware

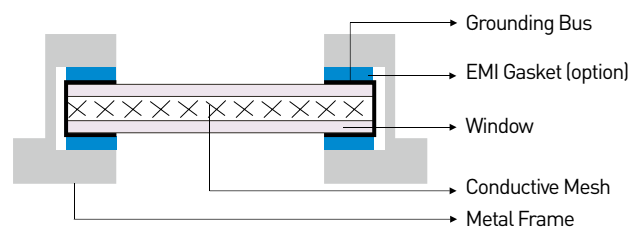

Quality Performance (SE)

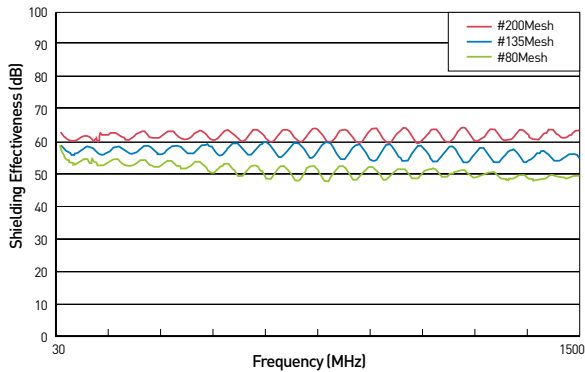

How to Order

P/N : IDW - AAA - BBB - CCC - DDD - EEE - FFF - GGG
 ① ② ③ ④ ⑤ ⑥ ⑦ ⑧

- ① Serial Number
- ② Width of Window (mm)
- ③ Height of Window (mm)
- ④ Thickness of Window (mm)
- ⑤ Numbers of Mesh Count & Mesh angle or ITO Coating
- ⑥ Coating option : AR, ITO
- ⑦ Color of Window
- ⑧ Grounding method

Option

● AR (Anti-Reflection) Coating

To minimize the glare, AR treatment on the substrate may be done. Right data have shown the transparency only for the AR acrylic sheet without conductive mesh. In case of using conductive mesh, the data will be changed

● ITO Coating

ITO coating proved a good EMI Shielding and optical transparency.

The electric conductivity is 2000 Ω /cm.

No moire type.

Maximum operating temperature is about 80 °C.

Total light transparency is approximately 75%.

The coating thickness of ITO is 500~600 Å.

Grounding Method

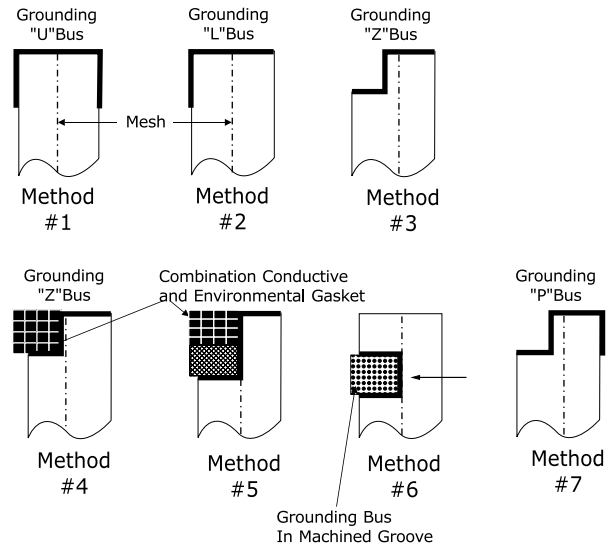

[For Example]

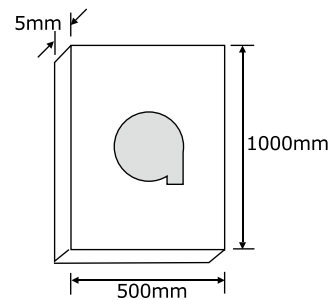

Example _ 1

- Color : Gray
 - Mesh Count : 135
 - Mesh Angle : 45°
 - Coating option : None
 - Grounding Method : #2
- ▶ IDW-500-1000-5.0-13545-N-Gray-#2

Example _ 2

- Color : Gray
 - Mesh Count : 80
 - Mesh Angle : 90°
 - Coating : AR
 - Grounding Method : #2
- ▶ IDW-500-1000-5.0-08090-AR-Gray-#2

Example _ 3

- Color : Gray
 - Mesh Count : None
 - Mesh Angle : None
 - ITO Coating
 - Coating option : AR
 - Grounding Method : #2
- ▶ IDW-500-1000-5.0-ITO-AR-Gray-#2

EMI Air Vent Filter

- Air Vent Filter-Woven Mesh Type

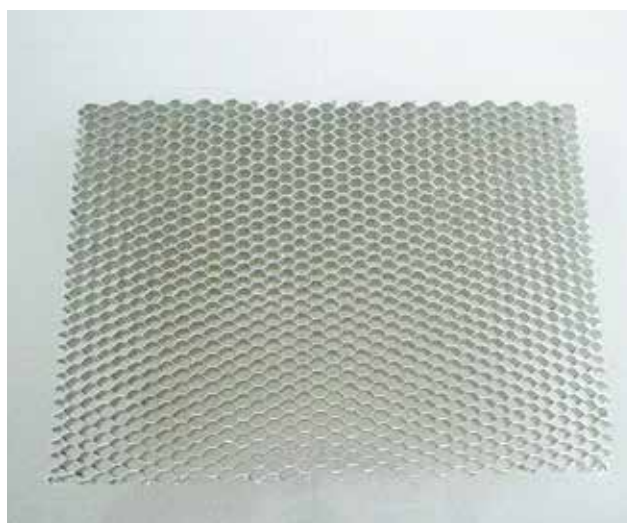

- Air Vent Filter-Honey Comb Type

Woven Mesh Filter

Honey Comb Filter (Al)

For Ventilating Openings

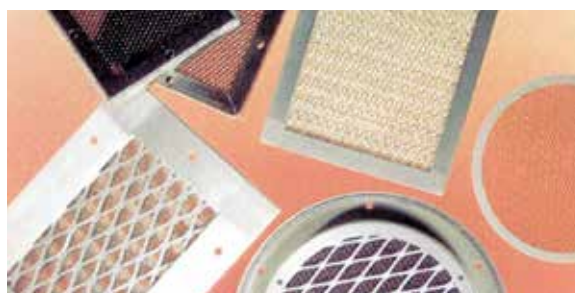

EMI Air Vent Filter

Features

EMI Air Vent Filter plays roles of both ventilation (heat discharge) and countermeasure against EMI in shield rooms, chambers, electronic enclosures and so on.

The choice of material for EMI Air Vent Filter is greatly determined by EMI SE, performance of heat discharge and dimension of devices.



Applications

- Network Server
- Personal Computer
- Cooling Fan Cover
- Access Equipment
- High Speed Routers
- Storage Cabinets

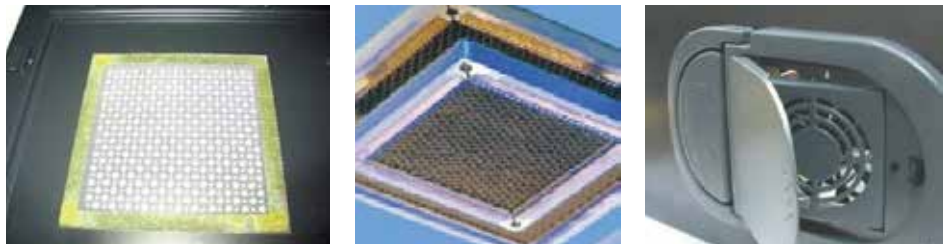

Characteristics

1. Honeycomb Type

Frame	Extrusion Aluminum Chromated
EMI Filter	Honeycomb/Aluminum MIL C 7438 Alloy 5052
EMI Gasket	Option

Structure & Dimensions

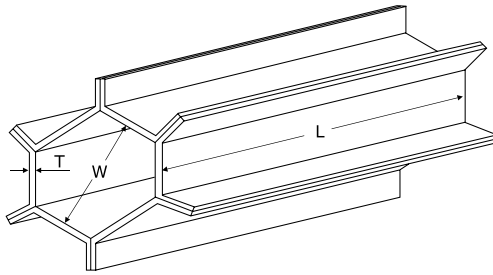

W(mm)	L (mm)	T (mm)	Material
3.18	12.7	0.05	Aluminum
3.18	6.4	0.05	Aluminum

Properties of Air Flow

The figure shows data on air flow characteristics of Honeycomb.

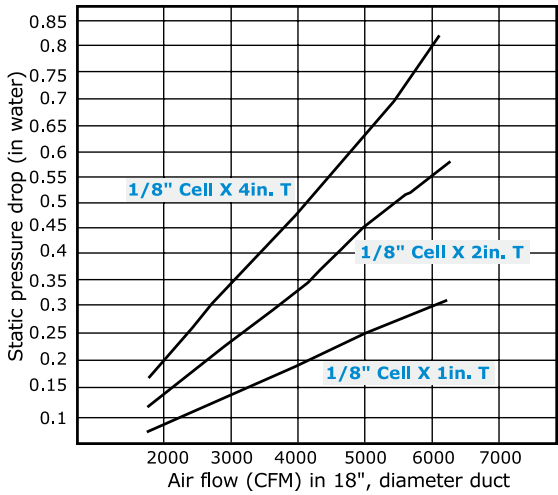

● Properties of Alloy 5052

- Features

Elevated Use Temp., High Thermal Conductivity, Flame Retardant,

Excellent Moisture and Corrosion Resistance, Fungi Resistance, Low Weight, High Strength

- Typical Properties [T : 0.05mm]

Honeycomb Designation			Bre. Compression		Plate Shear			
Cell Size (mm)	Foil Thickness (mm)	Density (kg/cm ³)	Strength (kgf/cm ²) [psi]	Modulus (kgf/cm ²) [ksi]	Strength ["A"] (kgf/cm ²) [psi]	Strength ["B"] (kgf/cm ²) [psi]	Modulus ["A"] (kgf/cm ²) [ksi]	Modulus ["B"] (kgf/cm ²) [ksi]
3.18	0.05	2	10.0 [142.1]	2511 [35.68]	5.20 [73.9]	3.27 [46.5]	968 [13.8]	388 [5.5]

2. Wire Mesh Type

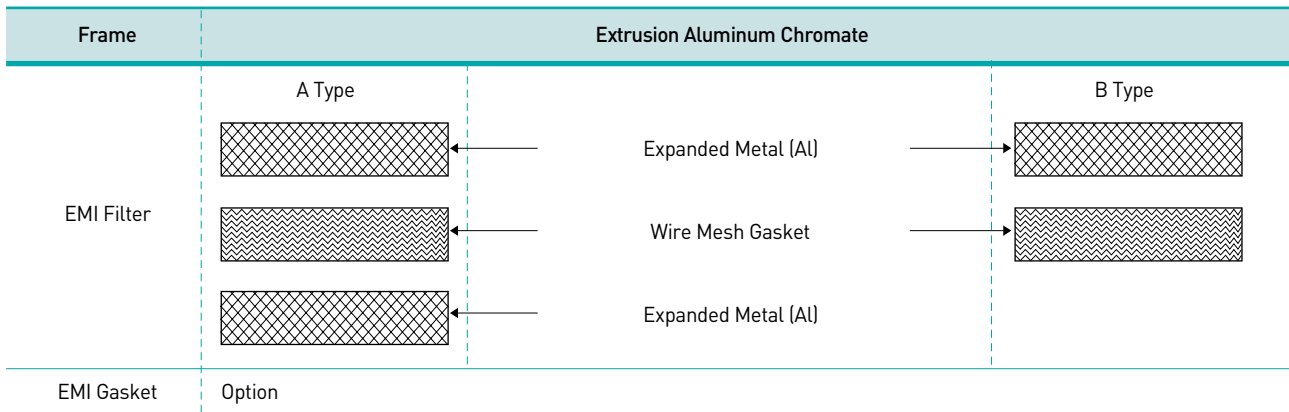

■ Structure (Expanded Metal over Honeycomb or Wire Mesh Filter is Option)

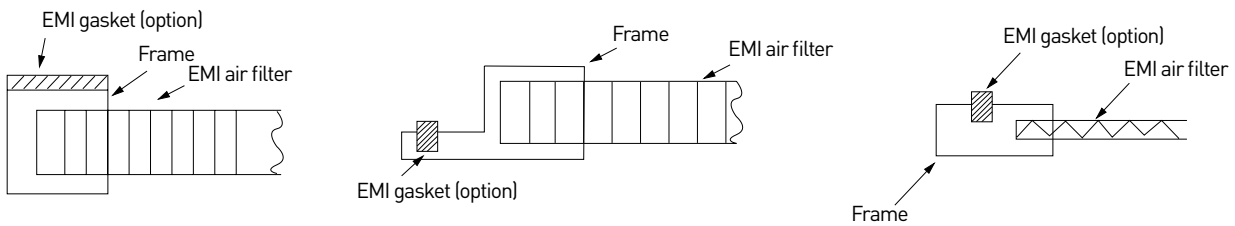

01
02
03
04
05
06
07
08
09
10

11 _ EMI Air Vent Filter

How to Order

P/N : IDHC(C) - AAA - BBB - CCC - DDD - EEE - FFF

- ① Serial Number: HC (Honeycomb),C3(Chromated)
- ② Frame : FL, FS, None (No Frame)
- ③ Material : AL (Aluminum)
- ④ XXX size (mm)
- ⑤ YYY size (mm)
- ⑥ ZZZ size (mm)
- ⑦ EMI Gasket Option

[For Example]

IDHC-FL-AL-200-150-9.6T-Wire Gasket (Monel)

[Frame Type]

IDHC-AL-200-150-6.4T

[No Frame]

How to find DI materials

Head Quarter & Ansan Factory

36, Ansantekom 1-gil, Sangnok-gu, Ansan-si, Gyeonggi-do, Republic of Korea
경기도 안산시 상록구 안산테크콤1길 36 (사사동)



Banwol Factory

98-10, Neungan-ro, Danwon-gu, Ansan-si, Gyeonggi-do, Republic of Korea
경기도 안산시 단원구 능안로 98-10

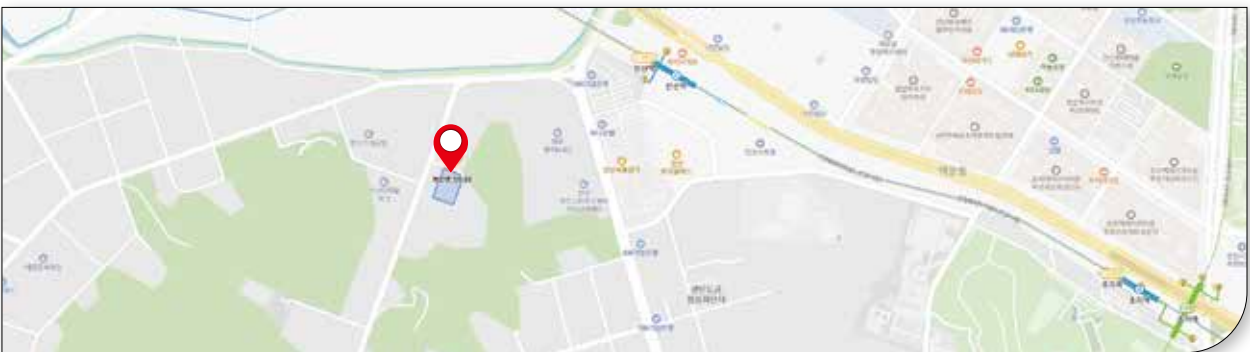

Gumi Business Office

6, Indong 54-gil, Gumi-si, Gyeongsangbuk-do, Republic of Korea
경북 구미시 인동54길6(구평동1036)



DI materials Vietnam Corp.

Lot CN1-2 and CN1-3, Yen Phong Industrial Park (expansion phase),
Yen Trung and Dung Liet Communes, Yen Phong District, Bac Ninh Province, Vietnam



■ **Head Quarter & Ansan Factory**

Add 36, Ansantekom 1-gil, Sangnok-gu, Ansan-si, Gyeonggi-do, Republic of Korea

Head Office Tel_ +82-31-415-0433 Fax_ +82-31-415-0434 E-mail_ dim@dimaterials.co.kr

Homepage_ www.dimaterials.co.kr